

Signal Transmitters, Isolators and Converters

One Isolator Can Take the Place of Two

Problem: We have a project to expand our plant that includes monitoring of many non-isolated process signals. We're looking for high density DIN mounting, low cost and high performance.

Solution: The dual-channel ECT offers two independent, high performance isolation channels in one enclosure. The pricing, high density mounting capability and simplified wiring add up to big savings for your application.

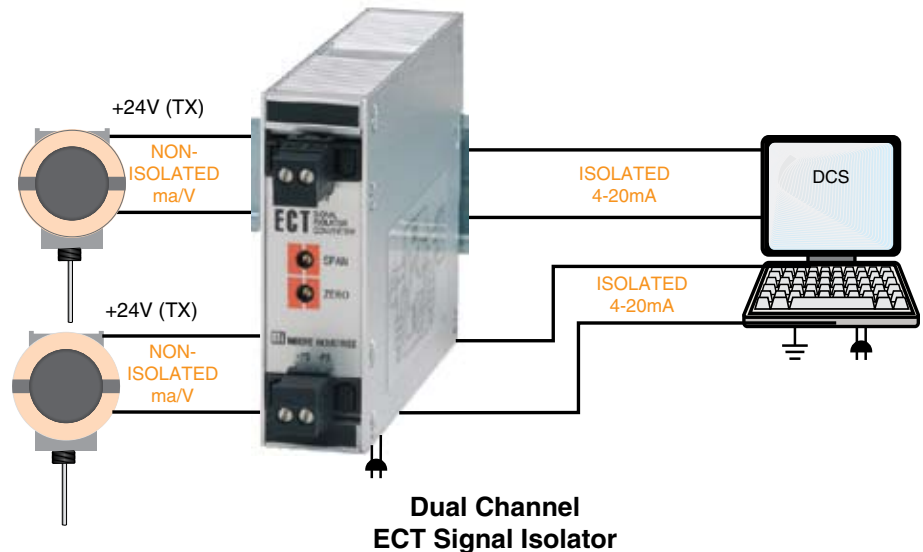

Model Number Example

ECT / 2X4-20MA / 2X4-20MA / 117AC / -TX [DIN]

[Go to Signal Transmitters, Isolators and Converters Selection Guide](#)