



May 2016
221-703-00 E

240 Milliamp
DIN-style Power Supply

DPS

DPS
*240 Milliamp
DIN-style Power Supply*

Table of Contents

Introduction	1
Description	1
Calibration	3
Installation	5
Troubleshooting	7

48^{HR.} DELIVERY



United States/Canada
TOLL FREE
1-800-999-2900

16650 Schoenborn Street
Sepulveda, California 91343, U.S.A.
Tel: (818) 894-7111 • Tlx: 65-1322
FAX: (818) 891-3297
CONNECT (MacNet): MIISEPULVEDA

United Kingdom
FREE PHONE
0800 525107

18 Royce Road, Crawley
W. Sussex RH10-2NX, United Kingdom
Tel: 0293 514488 • Tlx: 87667
FAX: 0293 36852

Australia
TOLL FREE
008 251928

3/18 Resolution Drive, Caringbah
New South Wales 2229, Australia
Tel: (02) 525-9177 • Tlx: 790-75914
FAX: (02) 525-7296

Ask for the STAR Center

Moore Industries' STAR[®] Center has a wide variety of quality instrumentation in stock and ready to ship.

- Signal Transmitters
- Temperature Transmitters
- P/I and I/P Converters
- Isolators and Converters
- Indicators and Displays
- Alarm Trips
- Integrators and Totalizers
- Power Transducers
- Instrument Power Supplies
- Racks, Rails and Enclosures

Most instruments can be customized to meet your needs. Even then, you'll never have to wait more than a few days.

Moore Industries

STAR
CENTER

* Support, Technical Assistance, and Repair (our Quick-Ship Facility)

Introduction

The DPS 240 is Moore Industries' 240 milliamp (mA) DIN-style Power Supply. It is a highly accurate, adjustable unit, most often used to power 2-wire transmitters. It is also ideal for use with data communications modules like Moore Industries' Link Converter Module (LCM), or Redundant Link Module (RLM).

Unit features include continuous short circuit and short-term overload protection, input/output isolation, and a derated circuit design for added dependability.

This manual contains the description, specifications, calibration information, and installation procedures for the DPS 240.

Description

The DPS 240 is a compact unit; particularly well-suited for use in industrial environments where available installation space is at a premium. It is enclosed in a standard, DIN-style, aluminum housing designed to be installed on a standard "G-rail" (not included). This rail can then be mounted on a wall, in a rack, or in a NEMA enclosure. Each DPS 240 is capable of powering twelve 4-20 mA loops.

The front panel of the the unit features potentiometers for adjustment of voltage and current limit, test jacks for auxiliary connection of calibration equipment, and a red LED indicator that lights when dc output is present.

The terminal blocks, three for input and eight for output, can be set into either the front or rear panel, according to customer specification.

The unit is available in 24- or 42-Vdc output configurations. A potentiometer on the front panel allows for adjustment of the output $\pm 5.0\%$.

Input voltage can also be specified by the customer, and is available set to 117, 220, or 240 Vac, 50/60 Hz.

The equipment specifications for the DPS 240 are listed in table 1.

Serial Number. A complete, serial-number-dependent history is kept on every unit that Moore Industries sells and services. For service information, provide the factory with the serial number of the unit that requires attention. The serial number is stamped on a label, and affixed to the side panel.

Model Number. Moore Industries' model numbers identify the type of instrument, functional characteristics, any options ordered, and the housing type. The model number reflects the way the unit was configured when it originally left the factory. It is all that is needed to identify the operational characteristics of the power supply. The number appears on the same label as the serial number.

The following example outlines the significance of each field in a typical DPS 240 model number.

DPS

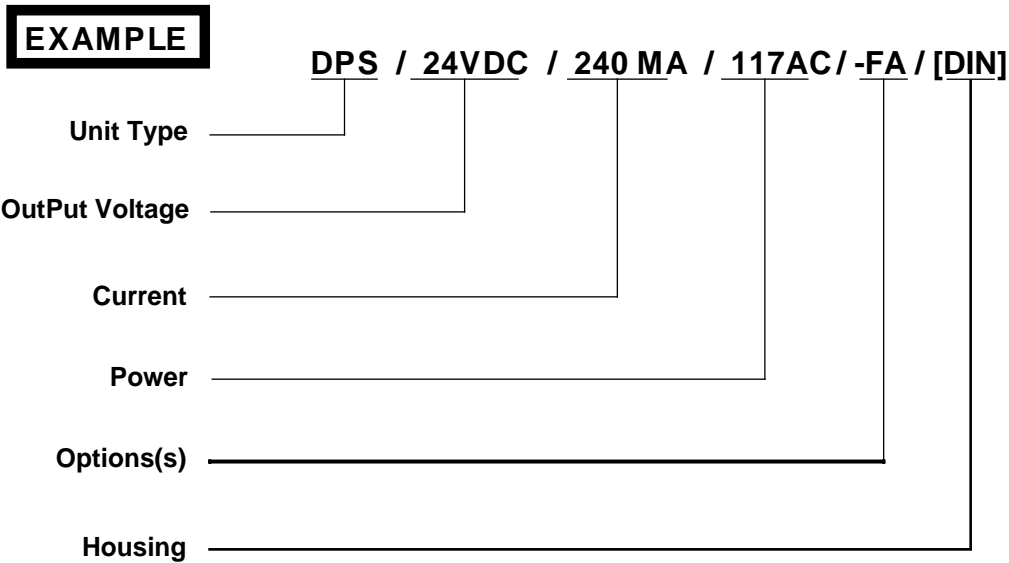

Table 1. DPS 240 Equipment Specifications

Characteristics	Specifications
Input Power	117, 220, or 240 Vac (factory-configured according to customer requirement)
Input Frequency	48 to 62 Hz Supply Type: Linear
Output	24 or 42 Vdc, 240 mA (factory-configured according to customer requirement), adjustable $\pm 5.0\%$ with front panel potentiometers Regulation: 0.5% maximum, low line to high line
Performance Efficiency	70% typical, rated at full load Load: 1.0% maximum, no load to full load Ripple: 50 mV peak-to-peak, maximum Isolation: Input/Output/Unit Housing = 1100 Vrms
Environmental Conditions	Ambient Temperature Operating Range: 0 to +70 °C (+32 to +158 °F) Effect on Unit: $\pm 0.03\%$ per °C over the range specified
Weight	765 grams (1 pound, 11 ounces)
NOTE: Refer to the Installation Section of this manual for unit dimensions.	

Calibration

Each power supply is calibrated and checked at the factory to ensure proper performance before shipping. However, output values for each unit should be checked by the user on-site before the equipment is placed into service.

Indicators

There is a red LED indicator on the front panel of the DPS 240, which lights when the unit is producing dc output. The indicator, labeled "OUTPUT ON", goes out if a short circuit, overload, or any other unacceptable condition occurs during operation.

Controls

The unit's front panel has two multiturn potentiometers labeled "VOLTAGE ADJUST" and "CURRENT LIMIT". Voltage adjust allows the user to set dc output to $\pm 5.0\%$ of the rated value. Using the current limit potentiometer, the user can calibrate the unit so that the output voltage stays within the specified range, even when input varies $\pm 10\%$. This protects the DPS 240 from possible damage due to overheating.

Refer to table 1 for the equipment specifications of the DPS 240.

Calibration Equipment

Table 2 lists the equipment required to calibrate the DPS 240. This equipment must be provided by the user.

Table 2. Calibration Equipment

Equipment	Description
Adjustable ac Power Source	Variac or equivalent; capable of 105-264 Vac output
Voltmeter	Accurate to 0.01 millivolt
Milliammeter	Accurate to 1.0 milliamp
Variable Power Resistor	Powerstat, or equivalent; capable of output load of 175 \dot{y}
Screwdriver, slotted	Head measuring less than 2.54 mm (0.1 inch) in width

DPS

Calibration Setup

Calibration should be performed in a laboratory setting. This will allow the user to control input variables, and to monitor changes in the output more easily. Figure 1 depicts the correct calibration setup for the DPS 240.

Before beginning to the calibration itself, connect the unit as shown, and set the load to 100 ohms for 24Vdc units, or 175 ohms for 42 Vdc units.

Apply the appropriate ac power to the setup (117, 220, or 240 Vac). The specifications table and the model number printed on the serial tag list the acceptable input power levels for the unit being calibrated.

When power is applied, the front panel "OUTPUT ON" LED will light, indicating the presence of dc output.

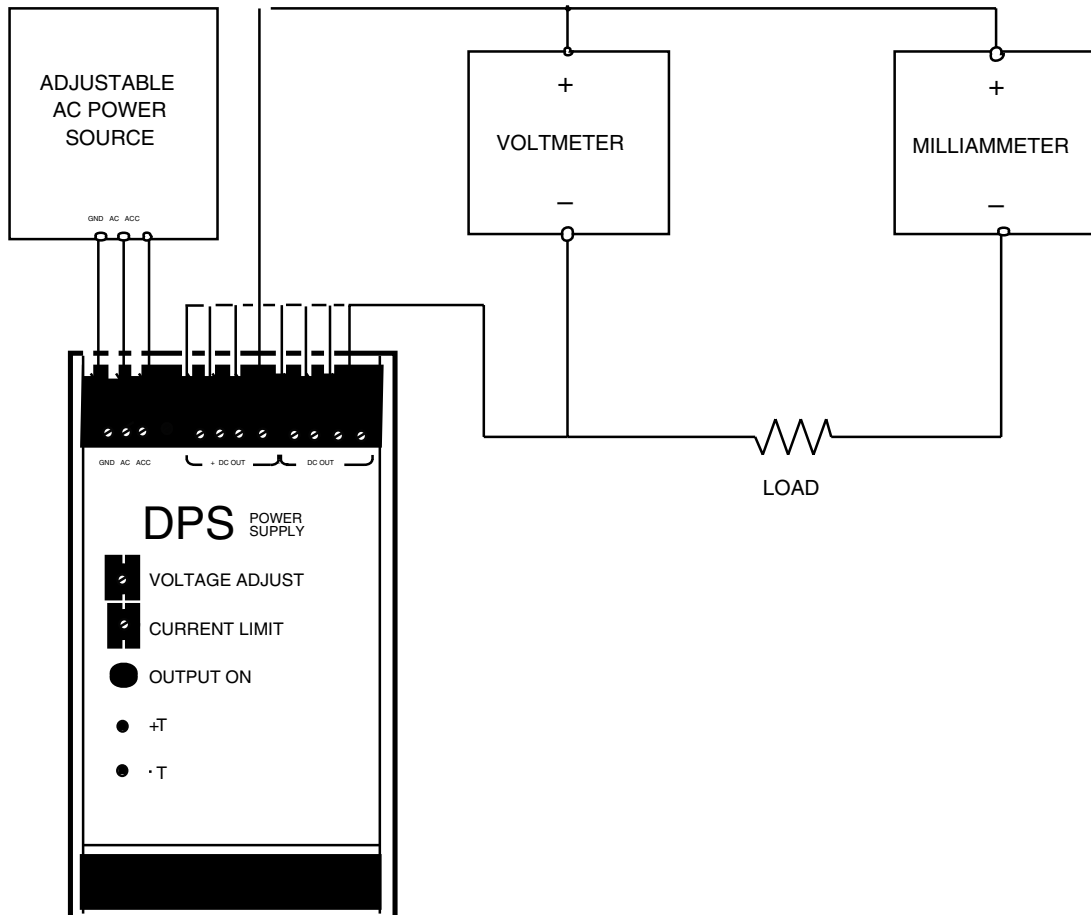

Figure 1. DPS 240 Calibration Setup

Calibration Procedure

To calibrate the DPS 240:

1. Turn CURRENT LIMIT potentiometer fully clockwise.
2. Vary setting of VOLTAGE ADJUST potentiometer from fully clockwise to fully counterclockwise. Note output reading at each extreme. Available voltage range will equal $\pm 5.0\%$ of unit's rated output voltage (23.8 to 25.2 Vdc for 24-Vdc models, or 39.9 to 44.1 Vdc for 42-Vdc models).
3. Use VOLTAGE ADJUST potentiometer to set output voltage to maximum specified for the unit being calibrated, ± 10 millivolts (24, or 42 Vdc, as appropriate).
4. Reset load to 91 Ω , or until the milliammeter reads 264 mA (+10% of the maximum rated current output for the DPS 240).
5. Turn CURRENT LIMIT potentiometer counterclockwise until output voltage drops to 23.88 Vdc for 24 Vdc units, or 41.79 Vdc for 42 Vdc units (99.5% of appropriate nominal output level).
6. Reset load so that current output is 240 mA.
7. Short the output.

Red "OUTPUT ON" LED on unit's front panel will go out.
8. Hold short circuit in place for 1 minute, then remove it. Observe that the LED turns on, and that output voltage quickly returns to rated nominal, ± 10 mV (23.88 Vdc for 24-Vdc units, or 41.79 Vdc for 42-Vdc units).
9. Remove load. Observe that output voltage drop is less than 100 mV.
10. Re-apply load. Set it so that current output is 240 mA. Note output voltage reading at this setting.
11. Vary input voltage $\pm 10\%$. Observe that voltage varies less than 0.5%, low-line to high-line.
12. Use VOLTAGE ADJUST potentiometer to select output voltage desired. Disconnect voltmeter from terminal blocks, and re-connect leads to "+T" and "-T" test jacks on front panel of DPS 240.
13. Verify that reading at these test jacks is the same as for terminal block connections.
14. Remove ac input, and dismantle test setup.

The unit is now calibrated and ready to be placed into service.

Installation

Installing the DPS 240 consists of physically mounting the device, and then completing the necessary electrical connections.

Mounting

Although the DPS 240 is designed to employ convection cooling, it is advised to mount it on a surface made of material that can serve as a heat sink. Care should also be taken to locate the DPS 240 in an area that is protected from dust, moisture, and corrosive atmospheres.

Figure 2 shows the outline dimensions of the DPS 240.

To mount the unit, the DIN rail should be positioned so that the smaller of its two flanges is toward the top (see figure 2).

Tilt the unit slightly backward, and insert the spring flanges on the back panel under the top flange of the DIN rail. Push inward and down until the DPS 240 snaps into place.

To remove the unit, pull outward (from the bottom) and up.

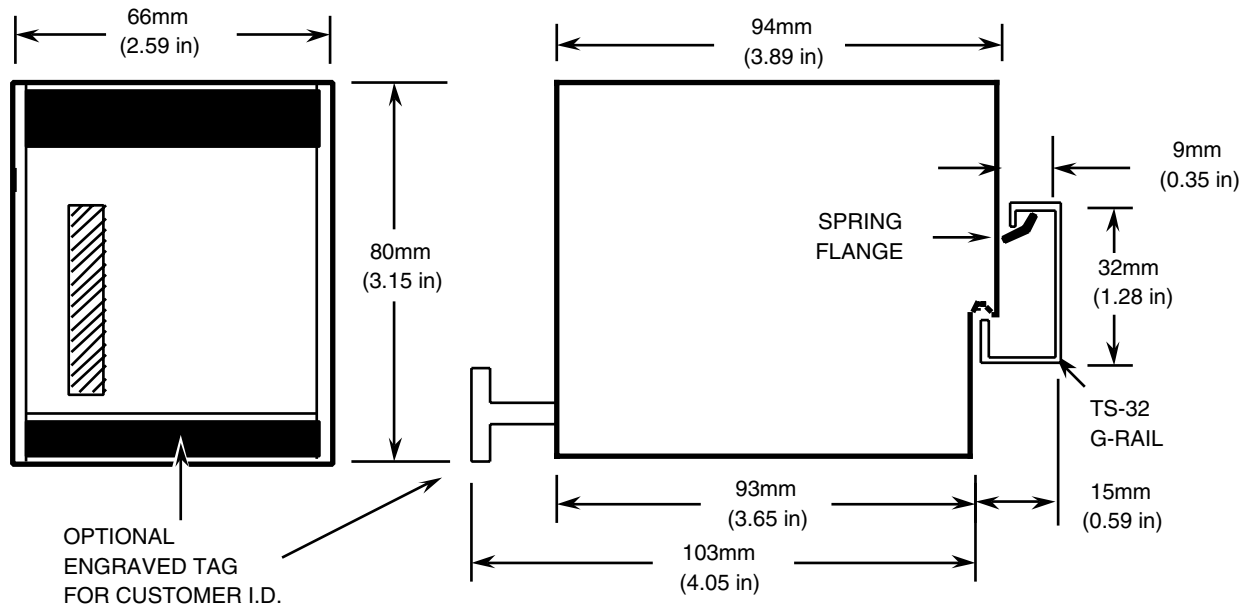

Figure 2. Outline Dimensions for the DPS 240

Electrical Connections

Figure 3 shows the front panel of the DPS 240 in detail, and depicts its electrical connection in a typical application.

For information on the Moore Industries products that typically work with the DPS 240, contact your local sales representative, or Moore Industries' Customer Service Department.

The use of 14-22 AWG insulated copper wire is recommended in connecting the DPS 240 terminals. To avoid transients and stray pick-ups, it is recommended that twisted conductors be used when running close to other services. To ensure good contact,

strip 5/16 to 3/8 inches of the insulation from the end of the wire.

To connect the DPS 240, loosen the clamping screw of the appropriate terminal, and insert the uninsulated end of the wire into the socket. Tighten the screw while holding the wire in place. Finally, tag the wire for identification. Once supplied with the appropriate ac power, the DPS 240 will begin to operate.

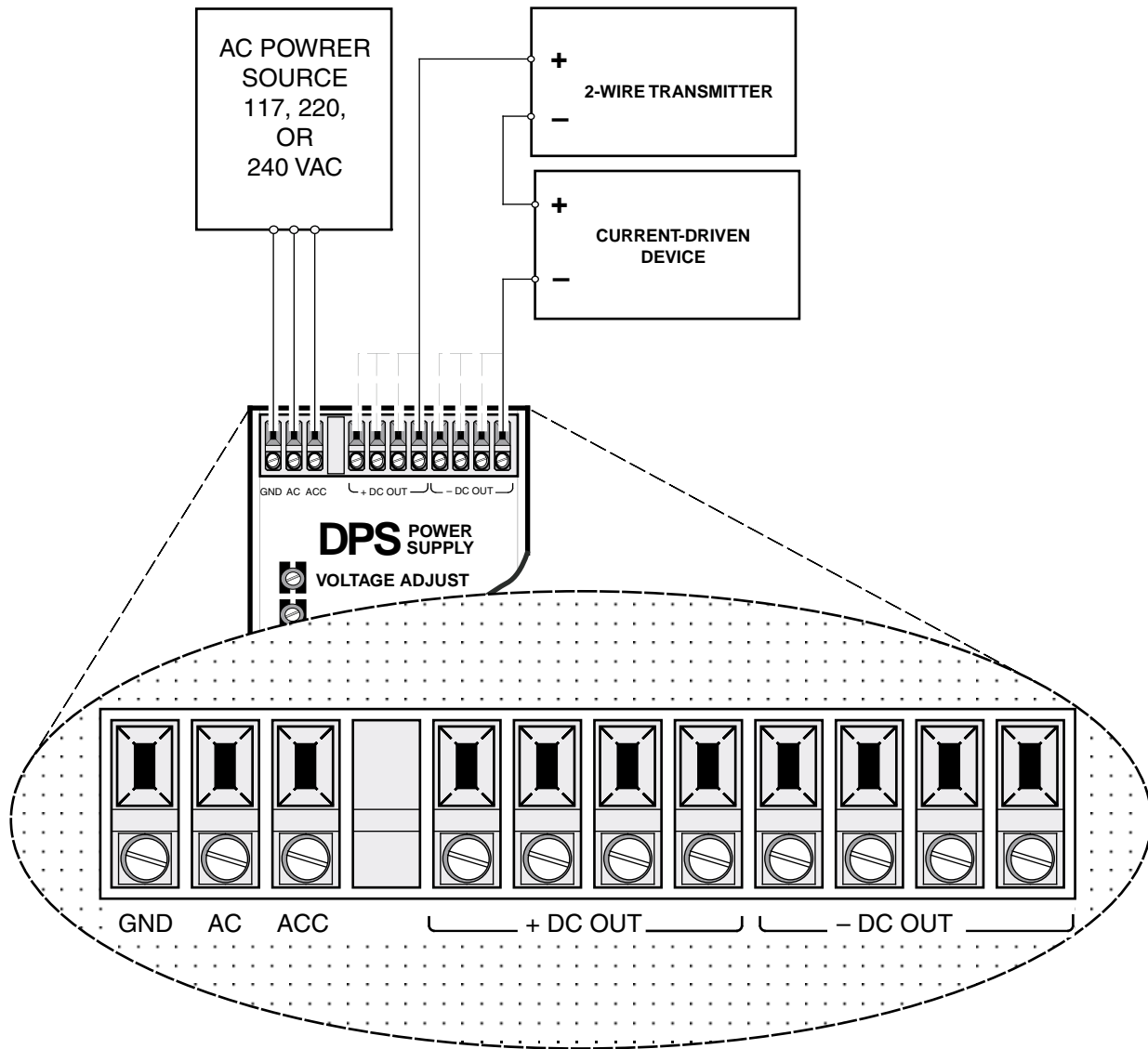

Figure 3. Typical Connection of the DPS 240

Troubleshooting

If a problem develops with the performance of the DPS 240, use the front panel test jacks to verify the proper output voltage. The probes should be 2.03 mm (0.08 in) in diameter, and 12.7 mm (0.50 in) long, maximum.

Connect a voltmeter to the appropriate test jacks, and re-adjust the output using the two adjustment potentiometers, VOLTAGE ADJUST and CURRENT LIMIT.

If problems continue, remove and recalibrate the unit. Refer to the Calibration section of this manual.

Any units found to be performing below specifications should be immediately returned to the factory for service. Instructions for return of the equipment are on the back cover of this manual. Customers may also contact Moore Industries' Customer Service Department at 1-800-999-2900 for assistance.

NOTES

RETURN PROCEDURES

To return equipment to Moore Industries for repair, follow these four steps:

1. Call Moore Industries and request a Returned Material Authorization (RMA) number.

Warranty Repair –

If you are unsure if your unit is still under warranty, we can use the unit's serial number to verify the warranty status for you over the phone. Be sure to include the RMA number on all documentation.

Non-Warranty Repair –

If your unit is out of warranty, be prepared to give us a Purchase Order number when you call. In most cases, we will be able to quote you the repair costs at that time. The repair price you are quoted will be a "Not To Exceed" price, which means that the actual repair costs may be less than the quote. Be sure to include the RMA number on all documentation.

2. Provide us with the following documentation:
 - a) A note listing the symptoms that indicate the unit needs repair
 - b) Complete shipping information for return of the equipment after repair
 - c) The name and phone number of the person to contact if questions arise at the factory
3. Use sufficient packing material and carefully pack the equipment in a sturdy shipping container.
4. Ship the equipment to the Moore Industries location nearest you.

The returned equipment will be inspected and tested at the factory. A Moore Industries representative will contact the person designated on your documentation if more information is needed. The repaired equipment, or its replacement, will be returned to you in accordance with the shipping instructions furnished in your documentation.

WARRANTY DISCLAIMER

THE COMPANY MAKES NO EXPRESS, IMPLIED OR STATUTORY WARRANTIES (INCLUDING ANY WARRANTY OF MERCHANTABILITY OR OF FITNESS FOR A PARTICULAR PURPOSE) WITH RESPECT TO ANY GOODS OR SERVICES SOLD BY THE COMPANY. THE COMPANY DISCLAIMS ALL WARRANTIES ARISING FROM ANY COURSE OF DEALING OR TRADE USAGE, AND ANY BUYER OF GOODS OR SERVICES FROM THE COMPANY ACKNOWLEDGES THAT THERE ARE NO WARRANTIES IMPLIED BY CUSTOM OR USAGE IN THE TRADE OF THE BUYER AND OF THE COMPANY, AND THAT ANY PRIOR DEALINGS OF THE BUYER WITH THE COMPANY DO NOT IMPLY THAT THE COMPANY WARRANTS THE GOODS OR SERVICES IN ANY WAY.

ANY BUYER OF GOODS OR SERVICES FROM THE COMPANY AGREES WITH THE COMPANY THAT THE SOLE AND EXCLUSIVE REMEDIES FOR BREACH OF ANY WARRANTY CONCERNING THE GOODS OR SERVICES SHALL BE FOR THE COMPANY, AT ITS OPTION, TO REPAIR OR REPLACE THE GOODS OR SERVICES OR REFUND THE PURCHASE PRICE. THE COMPANY SHALL IN NO EVENT BE LIABLE FOR ANY CONSEQUENTIAL OR INCIDENTAL DAMAGES EVEN IF THE COMPANY FAILS IN ANY ATTEMPT TO REMEDY DEFECTS IN THE GOODS OR SERVICES. BUT IN SUCH CASE THE BUYER SHALL BE ENTITLED TO NO MORE THAN A REFUND OF ALL MONIES PAID TO THE COMPANY BY THE BUYER FOR PURCHASE OF THE GOODS OR SERVICES.

ANY CAUSE OF ACTION FOR BREACH OF ANY WARRANTY BY THE COMPANY SHALL BE BARRED UNLESS THE COMPANY RECEIVES FROM THE BUYER A WRITTEN NOTICE OF THE ALLEGED DEFECT OR BREACH WITHIN TEN DAYS FROM THE EARLIEST DATE ON WHICH THE BUYER COULD REASONABLY HAVE DISCOVERED THE ALLEGED DEFECT OR BREACH, AND NO ACTION FOR THE BREACH OF ANY WARRANTY SHALL BE COMMENCED BY THE BUYER ANY LATER THAN TWELVE MONTHS FROM THE EARLIEST DATE ON WHICH THE BUYER COULD REASONABLY HAVE DISCOVERED THE ALLEGED DEFECT OR BREACH.

RETURN POLICY

For a period of thirty-six (36) months from the date of shipment, and under normal conditions of use and service, Moore Industries ("The Company") will at its option replace, repair or refund the purchase price for any of its manufactured products found, upon return to the Company (transportation charges prepaid and otherwise in accordance with the return procedures established by The Company), to be defective in material or workmanship. This policy extends to the original Buyer only and not to Buyer's customers or the users of Buyer's products, unless Buyer is an engineering contractor in which case the policy shall extend to Buyer's immediate customer only. This policy shall not apply if the product has been subject to alteration, misuse, accident, neglect or improper application, installation, or operation. THE COMPANY SHALL IN NO EVENT BE LIABLE FOR ANY INCIDENTAL OR CONSEQUENTIAL DAMAGES.



WORLDWIDE • www.miinet.com

United States • info@miinet.com
Tel: (818) 894-7111 • FAX: (818) 891-2816

Australia • sales@mooreind.com.au
Tel: (02) 8536-7200 • FAX: (02) 9525-7296

Belgium • info@mooreind.be
Tel: 03/448.10.18 • FAX: 03/440.17.97

The Netherlands • sales@mooreind.nl
Tel: (0)344-617971 • FAX: (0)344-615920

China • sales@mooreind.sh.cn
Tel: 86-21-62491499 • FAX: 86-21-62490635

United Kingdom • sales@mooreind.com
Tel: 01293 514488 • FAX: 01293 536852