



Process & Temperature Meter

330R2

User's Manual

All product names are registered trademarks of their respective companies.



Demand MOORE Reliability

Customer Support

Moore Industries is recognized as the industry leader in delivering top quality to its customers in products and services. We perform a sequence of stringent quality assurance checks on every unit we ship. If any Moore Industries product fails to perform up to rated specifications, call us for help. Our highly skilled staff of trained technicians and engineers pride themselves on their ability to provide timely, accurate, and practical answers to your process instrumentation questions. Our headquarters and other facilities phone numbers are listed below.

There are several pieces of information that can be gathered before you call the factory that will help our staff get the answers you need in the shortest time possible. For fastest service, gather the complete model and serial number(s) of the problem unit(s) and the job number of the original sale.

Locations

World Headquarters

16650 Schoenborn Street
North Hills, California
91343-6196, U.S.A.
Tel: (818) 894-7111
Fax: (818) 891-2816
E-mail: info@miinet.com
TOLL FREE: 1-800-999-2900
www.miinet.com

Europe

1 Lloyds Court, Manor Royal,
Crawley
W. Sussex RH10-9QU
United Kingdom
Tel: 01293 514488
Fax: 01293 387752
FREE PHONE: 0800 525107
sales@mooreind.com
www.miinet.com/uk

Australia

Sydney, NSW
3/1 Resolution Drive
Caringbah, New South Wales
2229
Australia
Tel: (02) 8536-7200
Fax: (02) 9525-7296
sales@mooreind.com.au
www.miinet.com/au

China

Room 102, No. 101,
Lane 1058,
Xinzhen Street, Xinqiao Town
Songjiang District,
Shanghai, 201612, P. R. China
Tel: 86-21 62491499
Fax: 86-21 62490635
E-mail: sales@mooreind.sh.cn
www.miinet.com

Benelux

Kontichsesteenweg 38A A01
2630 Aartselaar
Belgium
Tel: 03/448.10.18
Fax: 03/440.17.97
info@mooreind.be
www.miinet.com/dbe

Perth, WA
TOLL FREE: 1-800-784-899
sales@mooreind.com.au
www.miinet.com/au



www.miinet.com

Safety Messages

Please read this manual in its entirety. It should answer most of your questions. For personal and system safety, and for optimum product performance, make sure you thoroughly understand the contents before installing, using, or maintaining this product. Should you still have questions please visit our website at www.miinet.com or contact any of our sales/ support offices nearest you.

Your safety and the safety of others is very important. We have provided many important safety messages in this manual. Please read these messages carefully. These safety messages alert you to potential hazards that could hurt you or others or render damage to units.

All Moore Industries instrumentation should only be used for the purpose and in the manner described in this manual. If you use this product in a manner other than that for which it was intended, unpredictable behavior could ensue with possible hazardous consequences.

Each safety message is associated with a safety alert symbol. These symbols are found in and throughout the manual. The definition of these symbols is described below:

Pay particular attention wherever you see the following symbols:



Note – Information that is helpful for a procedure, condition or operation of the unit.



Caution – Hazardous procedure or condition that could damage or destroy the unit.



Warning – Hazardous procedure or condition that could injure the operator.

Qualified Personnel

The Moore Industries product/systems described in this manual may be operated only by personnel qualified for the specific task in accordance with the relevant documentation, in particular its warning notices and safety instructions. Qualified personnel are those who, based on their training and experience, are capable of identifying risks and avoiding potential hazards when working with these Moore Industries products/systems.

Proper use of Moore Industries products

Moore Industries products may only be used for the applications described in the catalog and in the relevant technical documentation. If products and components from other manufacturers are used, these must be recommended or approved by Moore Industries. Proper transport, storage, installation, assembly, commissioning, operation and maintenance are required to ensure that the products operate safely and without any problems. The permissible ambient conditions must be complied with. The information in the relevant documentation must be observed.

We have reviewed the contents of this publication to ensure consistency with the hardware and/or software described. Since variance cannot be precluded entirely, we cannot guarantee full consistency. However, the information in this publication is reviewed regularly and any necessary corrections are included in subsequent editions. Specifications and information are subject to change without notice.

All product and company names are trademarks™ or registered® trademarks of their respective holders. Use of them does not imply any affiliation with or endorsement by them unless otherwise specified.

Table of Contents

1	Introduction	8
2	Order Information	8
3	Specifications	10
3.1	General	10
3.2	Process Inputs	11
3.3	Temperature Inputs	11
3.4	Relays	12
3.5	Isolated 4-20 mA Transmitter Output.....	12
3.6	330-R2C-26 USB Adapter	13
4	Compliance Information.....	13
4.1	Safety.....	13
4.2	Electromagnetic Compatibility	13
5	EU Declaration of Conformity	14
6	Safety Information	14
7	Installation	15
7.1	Unpacking	15
7.2	Panel Mounting	15
7.3	Mounting Dimensions	16
7.4	Connections	16
7.4.1	Connector Labeling	16
7.4.2	Power Connections	17
7.4.3	Signal Connections	17
7.4.4	Relays and 24 V Output Connections.....	19
7.4.5	4-20 mA Output & Input Signal Connections	20
8	Setup and Programming.....	21
8.1	Overview	21
8.2	Front Panel Buttons and Status LED Indicators.....	21
8.3	Display Functions and Messages	22
8.4	Main Menu	23
8.5	Setting Numeric Values	24
8.6	Setting Up the Meter (SETU).....	24
8.6.1	Setting the Input Signal (INPT).....	25

Process & Temperature Meter

8.6.2	Setting the Decimal Point (<i>dc_Pt</i>).....	25
8.6.3	Setting the Temperature Scale (<i>F</i> \square <i>C</i>).....	26
8.7	Programming the Meter (<i>Prog</i>).....	26
8.7.1	Scaling the Meter (<i>ScAL</i>).....	26
8.7.2	Calibrating the Meter (<i>CAL</i>).....	27
8.7.3	Recalibrating Temperature Inputs (<i>CAL</i>).....	28
8.7.4	Recalibrating Process Inputs (<i>i CAL</i>).....	29
8.7.5	Setting the Relay Operation (<i>RELY</i>).....	29
8.7.6	Relay and Alarm Operation.....	32
8.7.7	Scaling the 4-20 mA Analog Output (<i>AOUt</i>).....	37
8.7.8	Program the Sensor Break Output Value (<i>SEbr</i>).....	37
8.7.9	Analog Output when Display is Out of Range.....	38
8.8	Setting Up the Password (<i>PASS</i>).....	38
8.8.1	Locking the Meter.....	38
8.8.2	Unlocking the Meter.....	38
8.9	Advanced Features Menu.....	39
8.9.1	Advanced Features Menu & Display Messages.....	39
8.9.2	Offset Adjustment (<i>Adj</i>).....	40
8.9.3	Noise Filter (<i>FLtr</i>).....	41
8.9.4	Noise Filter Bypass (<i>bYP5</i>).....	41
8.9.5	Select Menu (<i>SELC</i>).....	41
8.9.6	Linear or Square Root Function (<i>Linr</i> or <i>SqRt</i>).....	41
8.9.7	Low-Flow Cutoff (<i>CLtF</i>).....	42
8.9.8	Display Intensity (<i>INTY</i>).....	42
9	MeterView Software.....	43
9.1	Remote Programming.....	43
9.2	330-R2C-26 Meter to USB Serial Adapter.....	43
9.3	MeterView Installation.....	44
9.4	Running MeterView the First Time.....	44
9.4.1	Enable Meter and Select Meter Address.....	45
9.5	MeterView Main Window.....	45
9.5.1	Main Window Menus.....	46

Process & Temperature Meter

9.6	Configuration Window	48
9.6.1	File Menu	48
9.6.2	Tools Menu	48
9.6.3	Password Menu	49
9.6.4	Input Tab.....	49
9.6.5	Set Up Input Type	49
9.6.6	Set Up Decimal Point	49
9.6.7	Set Up Temperature Unit.....	50
9.6.8	Set Up Temperature Sensor.....	50
9.6.9	Scaling Tab	50
9.6.10	Relays/Alarms Tab.....	51
9.6.11	Advanced Tab	51
9.6.12	Info Tab.....	51
9.7	Customize Window.....	52
9.7.1	Internal Calibration (I CAL)	53
10	Operation	55
10.1	Front Panel Buttons Operation	55
10.2	Maximum/Minimum Readings	56
11	Troubleshooting.....	57
11.1	Diagnostics Menu (d iAG).....	57
11.1.1	Determining Software Version.....	57
11.2	Reset Meter to Factory Defaults	57
11.2.1	Factory Defaults & User Settings.....	58
11.3	Troubleshooting Tips.....	59
12	Quick Interface Reference Guide.....	60
13	330R2 Warranty Disclaimer	62

Table of Figures

Figure 1. Panel Cutout and Mounting	15
Figure 2. Meter Dimensions – Side View	16
Figure 3. Case Dimensions – Top View.....	16
Figure 4. Connector Labeling for 330R2/PRG/2PRG/HIACDC/-TX [P]	16
Figure 5. Connector Labeling for 330R2/PRG/2PRG/LOACDC [P].....	16
Figure 6. Connector Labeling for 330R2/PRG/2PRG/HIACDC/-AO-TX [P].....	17
Figure 7. Connector Labeling for 330R2/PRG/2PRG/LOACDC/-AO [P].....	17
Figure 8. Power Connections	17
Figure 9. Transmitter Powered by Internal Supply	17
Figure 10. Transmitter Powered by External Supply or Self-Powered.....	17
Figure 11. Voltage Input Connections.....	18
Figure 12. Thermocouple Input Connections	18
Figure 13. Three-Wire RTD Input Connections.....	18
Figure 14. Two-Wire RTD Input Connections	19
Figure 15. Four-Wire RTD Input Connections.....	19
Figure 16. Relay & 24 V Output Connections	19
Figure 17. 4-20 mA Output Powered by Meter.....	20
Figure 18. 4-20 mA Output Powered Externally.....	20
Figure 19. 330-R2C-26 USB Adapter Connections.....	44

1 Introduction

The 330R2 digital panel meter is one of the most versatile digital panel meters on the market and will satisfy a wide variety of process and temperature applications. The 330R2 can be field programmed to accept process voltage (0-5V, 1-5V, etc) and current (4-20 mA) inputs, 100 Ohm RTDs, and the four most common thermocouple types.

One of the most useful features of the 330R2 when it is AC powered is its ability to provide 24 VDC to power the transmitter's 4-20 mA signal. This reduces costs and simplifies wiring. The 330R2 is housed in a shallow-depth, 1/8 DIN enclosure that features a NEMA 4X front panel and convenient mounting hardware. There are two power options for the 330R2: **HIACDC** 85 to 265 VAC or 90 to 265 VDC and **LOACDC** 12-36 VDC or 12-24 VAC. The **HIACDC** powered meter can provide 24 VDC to power the transmitter, if needed.

Programming and setup can be performed with the four front panel pushbuttons or free MeterView software with the optional USB adapter.

Two relays are standard, and optional isolated 4-20 mA output options increase the utility of the 330R2 meter. The relays can be used for alarm or control applications. The 4-20 mA output provides an isolated retransmission of the input signal; especially useful for temperature inputs like thermocouples and RTDs.

The intensity of the display on the 330R2 can be adjusted to compensate for various lighting conditions, especially direct sunlight.

2 Order Information

HI PWR 85-265 VAC	Features
330R2/PRG/2PRG/HIACDC/-TX [P]	2 Relays, Transmitter Supply
330R2/PRG/2PRG/HIACDC/-AO-TX [P]	2 Relays 4-20 mA Output, Transmitter Supply
LO PWR 12-36 VDC	Features
330R2/PRG/2PRG/LOACDC [P]	2 Relays
330R2/PRG/2PRG/LOACDC/-AO [P]	2 Relays 4-20 mA Output

Accessories

Model	Description
330-R2SS-00	Stainless Steel Sun Hood
330-R2C-26	USB Serial Adapter for Programming Meter with MeterView Software

No More Sun Glare On Your Panel Meter Display!

1/8 DIN Panel Meter Stainless Steel Sun Hood

The 330-R2SS-00 Sun Hood improves the readability of 1/8 DIN digital panel meters when they are mounted in direct sunlight by shading the instrument from the sun.

The Sun Hood is made from 18 gauge 316 stainless steel and mounts between the 1/8 DIN digital panel meter and the panel. In addition, a gasket is provided that installs between the Sun Hood and the panel to provide a NEMA 4X seal to the panel. The whole assembly is held in place by the panel meter's mounting brackets.

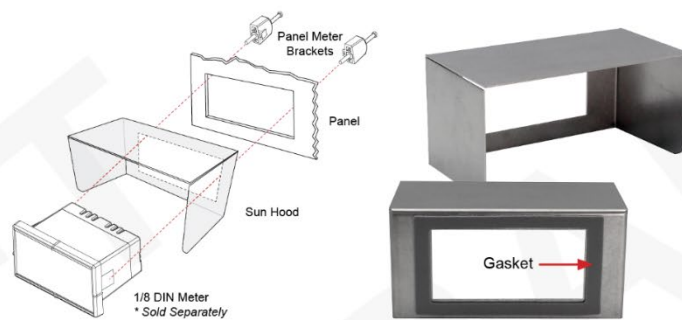

- Provides Shade for 1/8 DIN Digital Panel Meters
- Made from 18 Gauge 316 Stainless Steel
- Easy Mounting Requires no Drilled Holes in the Panel
- Includes Gasket to Maintain NEMA 4X Seal

SPECIFICATIONS

Model	330-R2SS-00
Material	18 gauge 316 stainless steel
Overall	2.99" x 5.68" x 2.99" (H x W x D)
Dimensions	(75 mm x 144 mm x 75 mm)
Weight	0.9 lb (0.4 kg)
Gasket Material	Silicone Foam

[Click here for more information on the 330-R2SS-00.](#)

Process & Temperature Meter**3 Specifications**

Except where noted all specifications apply to operation at +25°C.

3.1 General

Display	0.56" (14.2 mm), red LED, 4 digits (-1999 to 9999)
Display Intensity	Eight user selectable levels. Default intensity is 6.
Front Panel	NEMA 4X, IP65; panel gasket provided
Programming Methods	Four front panel buttons or PC with MeterView software
Noise Filter	Programmable from 2 to 199 (0 will disable filter)
Display Update Rate	Process/RTD: 3.7-5/second Thermocouple: 1.8-2.5/second
Overrange	Display flashes 9999
Underrange	Display flashes - 1999
Recalibration	All ranges are calibrated at the factory. Recalibration is recommended at least every 12 months.
Max/Min Display	Stored until reset by user or meter is turned off.
Password	Restricts modification of programmed settings.
Non-Volatile Memory	Settings stored for a minimum of 10 years.
Power Options	85-265 VAC, 50/60 Hz; 90-265 VDC, 20 W max or 12-36 VDC; 12-24 VAC, 6 W max.
Required Fuse	UL Recognized, 5 A max, slow-blow; up to 6 meters may share one fuse.
Normal Mode Rejection	64 dB at 50/60 Hz
Isolation	4 kV input/output-to-power line; 500 V input-to-output or output-to-24 VDC supplies. For 4-20 mA output models only: 100 V output-to-24 VDC supply
Operating Temperature	-40 to 65°C (-40 to 149°F)
Storage Temperature	-40 to 85°C (-40 to 185°F)
Relative Humidity	0 to 90% non-condensing
Connections	Power & Signal: removable screw terminal blocks accept 12 to 22 AWG. Serial: RJ11 header, standard on all meters.
Enclosure	1/8 DIN, high impact plastic, UL 94V-0, color: black
Tightening Torque	Screw terminal connectors: 5 lb-in (0.56 Nm)
Weight	9.5 oz. (269 g) (including options)
UL File Number	E539990; UL 508 Industrial Control Equipment
Warranty	3 years parts & labor. See Warranty Information and Terms & Conditions on www.miinet.com for complete details.

Process & Temperature Meter

3.2 Process Inputs

Inputs	0-20 mA, 4-20 mA, 1-5 V, ± 10 V	
Transmitter Supply	(AC powered units only) Isolated, 24 VDC $\pm 10\%$ @ 200 mA max	
Accuracy	$\pm 0.05\%$ FS ± 1 count; $\pm 0.1\%$ FS ± 2 counts for square root	
Function	Linear or square root	
Low-Flow Cutoff	0 to 9999 (0 disables cutoff function) Point below at which display always shows zero.	
Decimal Point	Up to 3 decimals.	
Calibration	Scale without signal or calibrate with signal source	
Calibration Range	User programmable over entire range of meter	
Input Impedance	Voltage range: greater than 1 M Ω , Current range: 50-100 Ω , varies with resettable fuse impedance	
Input Overload	Protected by automatically resettable fuse	
Temperature Drift	0 to 65°C ambient	-40 to 0°C ambient
	Current: $\pm 0.20\%$ FS (50 PPM/°C) Voltage: $\pm 0.02\%$ FS (1.7 PPM/°C)	Current: $\pm 0.80\%$ FS Voltage: $\pm 0.06\%$ FS

3.3 Temperature Inputs

Inputs	Factory calibrated, field selectable: type J, K, T, or E thermocouples and 100 Ω platinum RTD (0.00385 or 0.00392 curve)			
Resolution	1°; type T TC & RTD: 1° or 0.1°			
Cold Junction Reference	Automatic			
Temperature Drift	$\pm 2^\circ\text{C}$ maximum			
Offset Adjustment	Programmable to $\pm 19.9^\circ$. This parameter allows the user to apply an offset value to the temperature being displayed.			
Input Impedance	Greater than 100 k Ω			
Accuracy				
Input Type	Range	Accuracy (0 - 65 C)	Accuracy (-40 - 0 C)	Resolution
J	-58 to 1382°F -50 to 750°C	$\pm 2^\circ\text{F}$ $\pm 1^\circ\text{C}$	$\pm 5^\circ\text{F}$ $\pm 3^\circ\text{C}$	1°
K	-58 to 2300°F -50 to 1260°C	$\pm 2^\circ\text{F}$ $\pm 1^\circ\text{C}$	$\pm 4^\circ\text{F}$ $\pm 2^\circ\text{C}$	1°
T	-292 to 700°F -180 to 371°C	$\pm 2^\circ\text{F}$ $\pm 1^\circ\text{C}$	$\pm 13^\circ\text{F}$ $\pm 7^\circ\text{C}$	1° or 0.1°
E	-58 to 1700°F -50 to 927°C	$\pm 2^\circ\text{F}$ $\pm 1^\circ\text{C}$	$\pm 11^\circ\text{F}$ $\pm 6^\circ\text{C}$	1°
RTD	-328 to 1382°F -200 to 750°C	$\pm 1^\circ\text{F}$ $\pm 1^\circ\text{C}$	$\pm 5^\circ\text{F}$ $\pm 3^\circ\text{C}$	1° or 0.1°

Process & Temperature Meter

3.4 Relays

Rating	2 Form C (SPDT); rated 3 A @ 30 VDC or 3 A @ 250 VAC resistive load; 1/14 HP (≈ 50 watts) @ 125/250 VAC for inductive loads such as contactors, solenoids, etc.		
Deadband	0-100% FS, user selectable		
Electrical Noise Suppression	A snubber should be connected to each relay contact switching inductive loads to prevent disruption to the microprocessor's operation. Recommended snubber value: 0.01 μF/470 Ω, 250 VAC		
High or Low Alarm	User may program any alarm for high or low		
Relay Operation	<ul style="list-style-type: none"> • Automatic (non-latching) and/or manual reset • Latching (requires manual acknowledge) with/without clear • Pump alternation control • Off (disable unused relays) 		
Relay Reset	Front panel button		
Time Delay	0 to 199 seconds, on and off delays; programmable		
Sensor Break Relay Operation	<p>The sensor break relay condition may be programmed for each relay as On (alarm) or Off (nonalarm).</p> <p>The relays will enter these states when a sensor break is detected for RTD or thermocouple inputs. These settings have no effect when current or voltage inputs are selected.</p>		
Fail-Safe Operation	Programmable, independent for each relay. Relay coils are energized in non-alarm condition. In case of power failure, relays will go to alarm state.		
Auto Initialization	When power is applied to the meter, relays will reflect the state of the input to the meter.		

3.5 Isolated 4-20 mA Transmitter Output

Scaling Range	1.00 to 23.00 mA; reverse scaling allowed.		
Calibration	Factory calibrated for 4-20 mA		
Accuracy	±0.1% FS ±0.004 mA		
Temperature Drift	50 PPM/°C Note: Analog output drift is separate from input drift.		
Isolation	4 kV output-to-power line; 500 V input-to-output or output-to-24 VDC supplies. For 4-20 mA output models only: 100 V output-to-24 VDC supply		
External Power	35 VDC maximum		
Output Loop Resistance	Power supply	Minimum	Maximum
	24 VDC	10 Ω	700 Ω
	35 VDC (external)	100 Ω	1200 Ω

Process & Temperature Meter

3.6 330-R2C-26 USB Adapter

Purpose	To be used only for programming
Compatibility	USB 1.1, USB 2.0
Connectors	RJ11, and USB Type B
Cable	One 7' (2.1 m) standard modular cable and one 3.28' (1.0 m) USB A-B Male cable provided with adapter
Dimension	1.7" x 0.8" x 3.3" 43 mm x 21 mm x 83 mm) (W x H x D)
Distance	Adapter to: 330R2: 7' (2.1 m) max; USB connection to PC: 10' (3 m) max
Driver Compatibility	Microsoft® Windows® 7/10/11
Power	USB Port
Status Indication	Separate LEDs for Power (P), Transmit (TX), and Receive (RX)

4 Compliance Information

4.1 Safety

UL Listed	USA and Canada UL 508 Industrial Control Equipment
UL File Number	E539990
Front Panel	UL Type 4X, NEMA 4X, IP65; panel gasket provided
Low Voltage Directive	EN 61010-1 Safety requirements for measurement, control, and laboratory use

4.2 Electromagnetic Compatibility

Emissions	EN 55011 Group 1 Class A ISM emissions requirements
Radiated Emissions	Class A
AC Mains Conducted Emissions	Class A
Immunity	EN 61326-1 Measurement, control, and laboratory equipment EN 61000-6-2 EMC heavy industrial generic immunity standard
RFI - Amplitude Modulated	80 -1000 MHz 10 V/m 80% AM (1 kHz) 1.4 - 2.0 GHz 3 V/m 80% AM (1 kHz) 2.0 - 2.7 GHz 1 V/m 80% AM (1 kHz)
Electrical Fast Transients	±2kV AC mains, ±1kV other
Electrostatic Discharge	±4kV contact, ±8kV air
RFI - Conducted	10V, 0.15-80 MHz, 1kHz 80% AM
AC Surge	±2kV Common, ±1kV Differential
Surge	1KV (CM)
Power-Frequency Magnetic Field	30 A/m 70%V for 0.5 period
Voltage Dips	40%V for 5 & 50 periods 70%V for 25 periods
Voltage Interruptions	<5%V for 250 periods



Note: Testing was conducted on meters installed through the covers of grounded metal enclosures with cable shields grounded at the point of entry representing installations designed to optimize EMC performance.

5 EU Declaration of Conformity

For shipments to the EU and UK, a Declaration of Conformity was printed and included with the product. For reference, a Declaration of Conformity is also available on our website www.miinet.com/docs.

6 Safety Information



Note – Information that is helpful for a procedure, condition or operation of the unit.



Caution – Hazardous procedure or condition that could damage or destroy the unit.



Warning – Hazardous procedure or condition that could injure the operator.

7 Installation

There is no need to remove the meter from its case to complete the installation, wiring, and setup of the meter.

7.1 Unpacking

Remove the meter from box. Inspect the packaging and contents for damage. Report damages, if any, to the carrier.

If any part is missing or the meter malfunctions, please contact your supplier or the factory for assistance.

7.2 Panel Mounting

- Prepare a standard 1/8 DIN panel cutout – 3.622" x 1.772" (92 mm x 45 mm). Refer to *Mounting Dimensions* for more details.
- Clearance: allow at least 4" (102 mm) behind the panel for wiring.
- Panel thickness: 0.04" - 0.25" (1.0 mm - 6.4 mm).
Recommended minimum panel thickness to maintain Type 4X rating: 0.06" (1.5 mm) steel panel, 0.16" (4.1 mm) plastic panel.
- Remove the two mounting brackets provided with the meter (back-off the two screws so that there is 1/4" (6.4 mm) or less through the bracket. Slide the bracket toward the front of the case and remove).
- Insert meter into the panel cutout.
- Install mounting brackets and tighten the screws against the panel. To achieve a proper seal, tighten the mounting bracket screws evenly until meter is snug to the panel along its short side. **DO NOT OVER TIGHTEN**, as the rear of the panel may be damaged.

Figure 1. Panel Cutout and Mounting

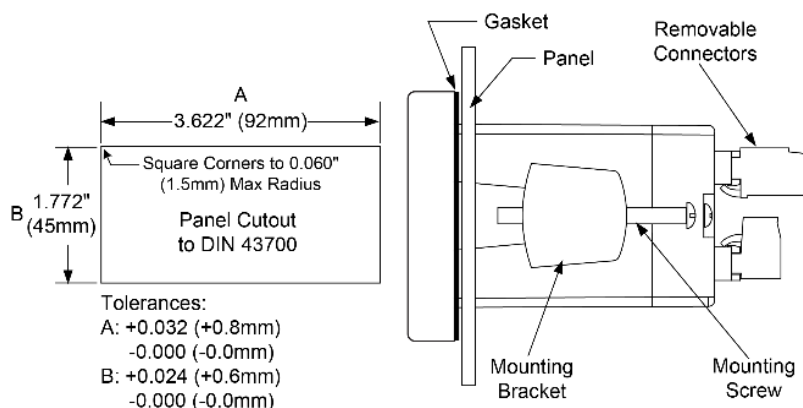

7.3 Mounting Dimensions

Figure 2. Meter Dimensions – Side View

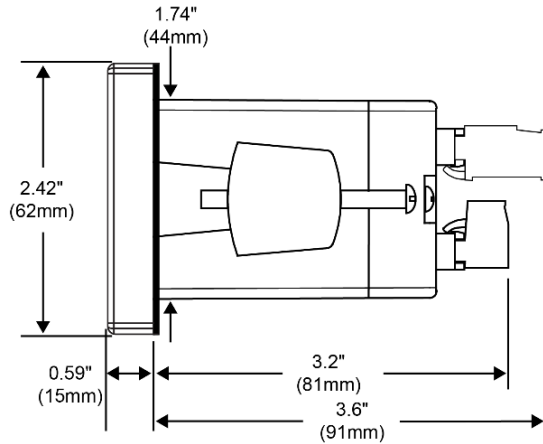
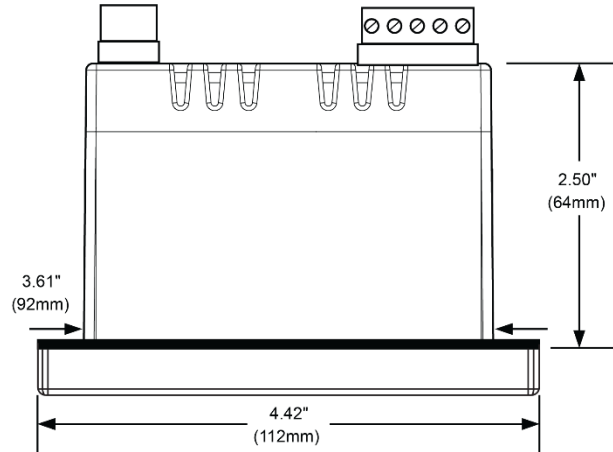

Figure 3. Case Dimensions – Top View



7.4 Connections

All connections are made to removable screw terminal connectors located at the rear of the meter.



Caution - Use copper wire with 60°C or 60/75°C insulation for all line voltage connections. Observe all safety regulations. Electrical wiring should be performed in accordance with all applicable national, state, and local codes to prevent damage to the meter and ensure personnel safety.

7.4.1 Connector Labeling

The connectors label, affixed to the meter, shows the location of all connectors available with requested configuration. It also identifies the location of the RTD/TC selector switch. The images below show all connector configurations for the 330R2. Note that the connector in the upper left of the diagram has different configurations based on the model.

Figure 4. Connector Labeling for 330R2/PRG/2PRG/HIACDC/-TX [P]

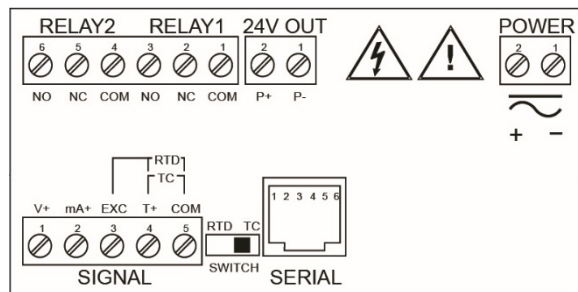
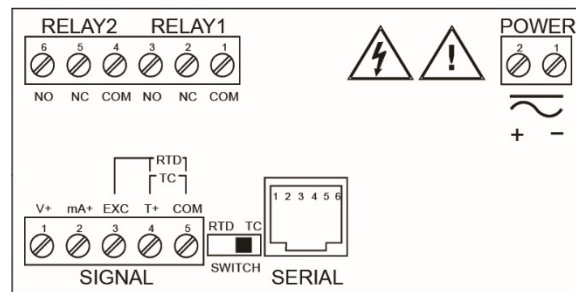

Figure 5. Connector Labeling for 330R2/PRG/2PRG/LOACDC [P]



Process & Temperature Meter

Figure 6. Connector Labeling for 330R2/PRG/2PRG/HIACDC/-AO-TX [P]

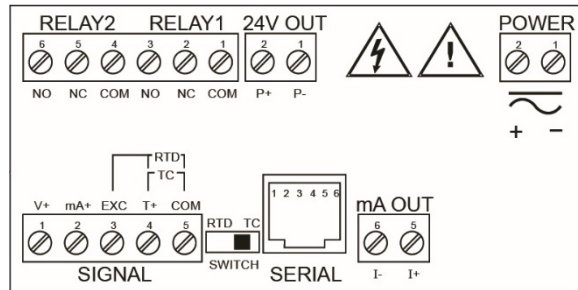
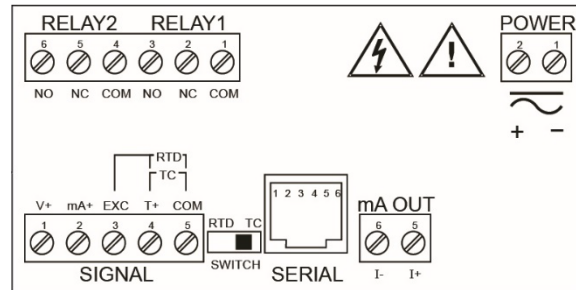

Figure 7. Connector Labeling for 330R2/PRG/2PRG/LOACDC/-AO [P]



7.4.2 Power Connections

Power connections are made to a two-terminal connector labeled POWER on Figures 4-21. See *Connector Labeling* on page 16. The meter will operate regardless of DC polarity connection. The + and - symbols are only a suggested wiring convention.

Figure 7. Power Connections

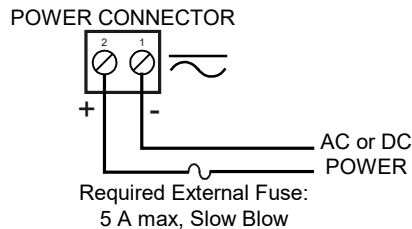

7.4.3 Signal Connections

Signal connections are made to a five-terminal connector labeled SIGNAL shown in Figures 4-21. See page 16. *Connector Labeling*. The COM (common) terminal is the return for all types of input signals.

Current and Voltage Connections

The following figures show examples for current and voltage connections.

There are no switches or jumpers to set up for current and voltage inputs. Setup and programming is performed through the front panel buttons.

Figure 8. Transmitter Powered by Internal Supply (Optional – AC Powered Units Only)

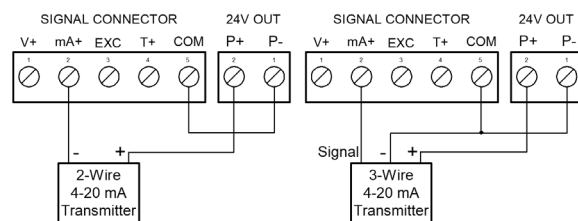
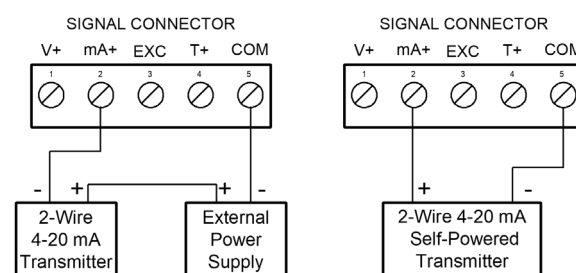

Figure 9. Transmitter Powered by External Supply or Self-Powered



Process & Temperature Meter

The current input is protected against current overload by a resettable fuse. The display may or may not show a fault condition depending on the nature of the overload.

The fuse limits the current to a safe level when it detects a fault condition, and automatically resets itself when the fault condition is removed.

Figure 10. Voltage Input Connections (Optional – AC Powered Units Only)

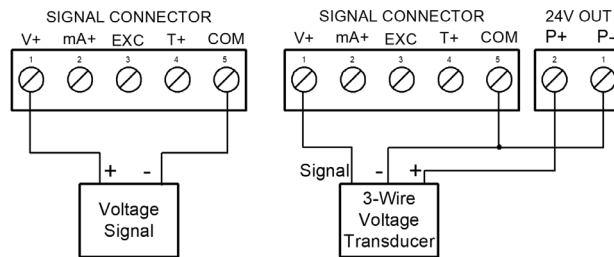

The meter is capable of accepting any voltage from -10 VDC to +10 VDC.

Thermocouple and RTD Connections

The following figures show examples for thermocouple and RTD connections.

The RTD/TC selector switch must be set to the proper position for the meter to accept the selected temperature input.

The input type is selected using the *Setup* menu.

The selected thermocouple input must correspond to the thermocouple sensor and wire type used.

Figure 11. Thermocouple Input Connections

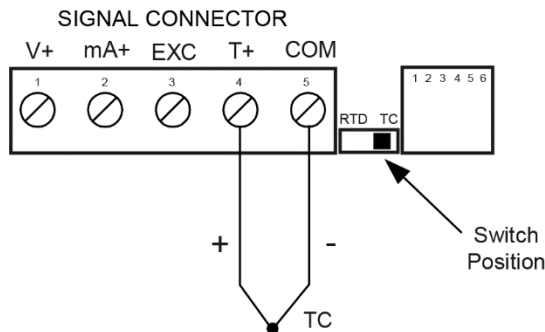
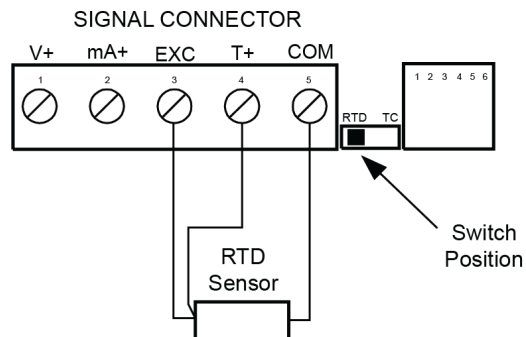

Figure 12. Three-Wire RTD Input Connections



The meter accepts two, three, or four-wire RTDs. The three-wire RTD connection has built-in lead wire compensation.

Process & Temperature Meter

Figure 13. Two-Wire RTD Input Connections

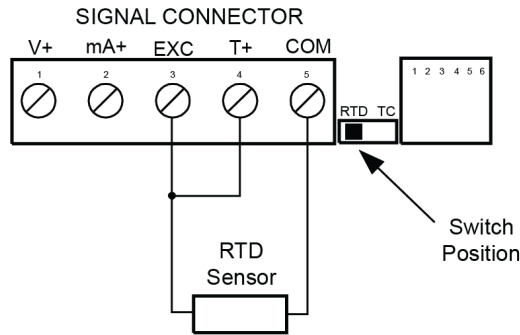

Lead wire compensation for two-wire RTDs can be applied using the *Adjust* menu. See *Offset Adjustment (Adj)* on page 40.

Figure 14. Four-Wire RTD Input Connections

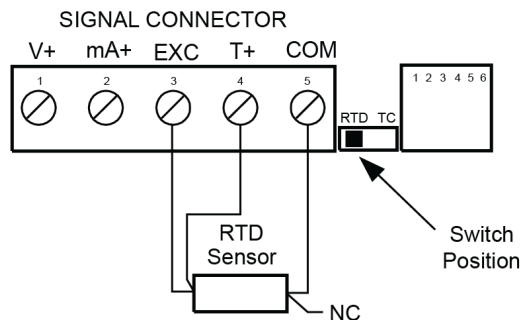

The four-wire RTD connection is similar to the three-wire. One of the leads of a four-wire RTD is not connected and may be clipped off.

The three-wire connection provides sufficient lead wire compensation to provide accurate readings even with long leads.

7.4.4 Relays and 24 V Output Connections

Relay connections are made to a six-terminal connector labeled RELAY1, RELAY2. See Figures under *Connector Labeling* on page 16. The COM (common) terminals of the relays should not be confused with the COM (common) terminal of the SIGNAL connector. The 24 VDC output is available at the connector labeled 24V OUT, next to the relays connector.

Figure 15. Relay & 24 V Output Connections

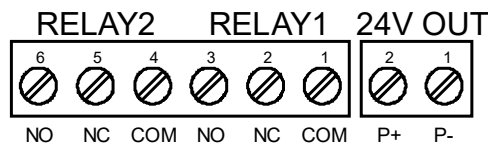

Process & Temperature Meter

7.4.5 4-20 mA Output & Input Signal Connections

The 330R2, with the 4-20 mA output option, can be used as an isolated temperature transmitter by converting the thermocouple or RTD input into an isolated 4-20 mA output.

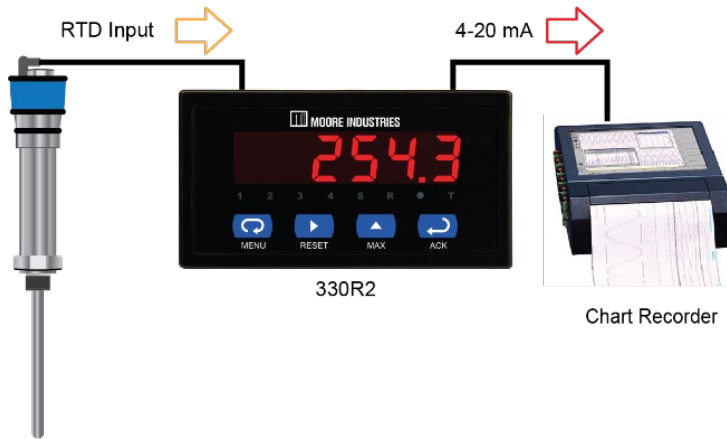

Connections for the 4-20 mA transmitter output are made to the connector terminals labeled “mA OUT: I-, I+”. The 4-20 mA output may be powered from an internal power supply (optional) or from an external power supply.

Figure 16. 4-20 mA Output Powered by Meter

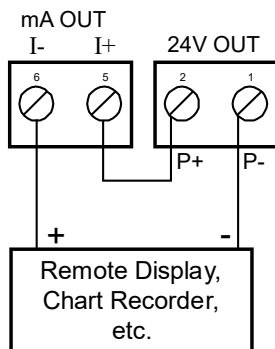
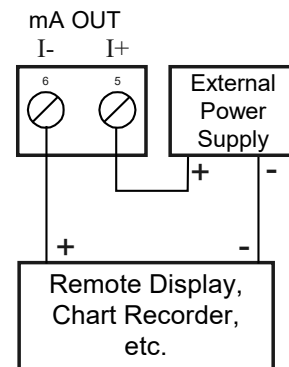

Figure 17. 4-20 mA Output Powered Externally



8 Setup and Programming

This section describes how to program the 330R2 meter using the front panel buttons. The 330R2 meter can also be programmed using *MeterView Software* as described on page **Error! Bookmark not defined.**



Caution: The unit must be powered down before accessing and changing these jumpers. Any changes to jumpers are only recognized by the unit on power up.

8.1 Overview

There are no jumpers involved in the setup process of the meter. The RTD/TC selector switch, located between the SIGNAL and SERIAL connectors, must be set accordingly for the meter to accept RTD or thermocouple inputs. See Figures under *Connector Labeling* on page 16.

Setup and programming is done through the front panel buttons.

After power and signal connections have been completed and verified, apply power to the meter.



For Quick Interface Reference Guide go to page 59.

8.2 Front Panel Buttons and Status LED Indicators

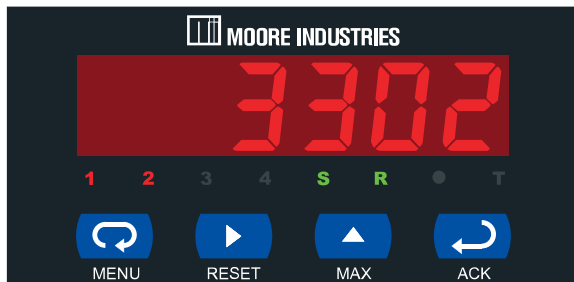

Button Symbol	Description
	Menu
	Right arrow / Reset
	Up arrow / Max
	Enter / Ack

LED	Status
1	Alarm 1
2	Alarm 2
S	Set point indicator
R	Reset point indicator

- Press the **Menu** button to enter or exit the Programming Mode at any time.
- Press the **Right** arrow button to move to the next digit during digit programming.
- Press the **Up** arrow button to scroll through the menus, decimal point, or to increment the value of a digit.
- Press the **Enter/Ack** button to access a menu or to accept a setting.
- Press the **Right** arrow and **Menu** button simultaneously or hold the **Menu** button for approximately 3 seconds to access the *Advanced Features Menu* of the meter.

Process & Temperature Meter

8.3 Display Functions and Messages

The meter displays various functions and messages during setup/programming and operation. The following table shows the displayed functions and messages with their action/setting description.

Display	Parameter	Action/Setting
SEtU	Setup	Enter Setup menu
inPt	Input	Enter Input menu
4-20	4-20 mA	Set meter for 4-20 mA input
0-10	0-10 VDC	Set meter for ± 10 VDC input
rtd	RTD	Set meter for RTD input
A385	Alpha 385	Set $\alpha = 0.00385$ European curve 100 Ω RTD
A392	Alpha 392	Set $\alpha = 0.00392$ American curve 100 Ω RTD
tC	TC	Set meter for TC input
0 J	0 J	Type J
1 K	1 K	Type K
2 T	2 T	Type T
3 T.0	3 T.0	Type T, 0.1 $^\circ$ resolution
4 E	4 E	Type E
F C	$^\circ\text{F}$ or $^\circ\text{C}$	Set temperature scale
$^\circ\text{F}$	$^\circ\text{F}$	Set meter to Fahrenheit
$^\circ\text{C}$	$^\circ\text{C}$	Set meter to Celsius
dEc_P	Decimal point	Set decimal point
Prog	Program	Enter the Program menu
ScAL	Scale	Enter the Scale menu
CL	Calibrate	Enter the Calibrate menu
inP1	Input 1	Calibrate input 1 signal or program input 1 value
d.S1	Display 1	Program display 1 value
inP2	Input 2	Calibrate input 2 signal or program input 2 value
d.S2	Display 2	Program display 2 value
Err	Error	Error, calibration not successful, check signal
RELY	Relay	Enter the Relay menu
rLY1	Relay 1	Relay 1 setup
Act1	Action 1	Set relay 1 action (automatic, latching, etc.)
AutO	Automatic	Set relay for automatic reset
A-M	Auto-manual	Set relay for automatic + manual reset any time
LtCH	Latching	Set relay for latching operation
L-CL	Latching-cleared	Set relay for latching operation with manual reset only after alarm condition has cleared
ALtr	Alternate	Set relays for pump alternation control
oFF	Off	Disable relay and front panel status LEDs Disable relay's fail-safe operation
SEt1	Set 1	Program set point 1
rSt1	Reset 1	Program reset point 1
rLY2	Relay 2	Setup relay 2
Act2	Action 2	Set relay 2 action (automatic, latching, etc.)
SEt2	Set 2	Program set point 2
rSt2	Reset 2	Program reset point 2

Process & Temperature Meter

Display	Parameter	Action/Setting
FLSF	Fail-safe	Enter <i>Fail-safe</i> menu
FLS1	Fail-safe1	Set relay 1 fail-safe operation
on	On	Enable fail-safe operation
oFF	Off	Disable fail-safe operation
FLS2	Fail-safe2	Set relay 2 fail-safe operation
dLAY	Delay	Enter <i>Time Delay</i> menu
dLY1	Delay 1	Enter relay 1 time delay setup
On1	On 1	Set relay 1 On time delay
OFF1	Off 1	Set relay 1 Off time delay
dLY2	Delay 2	Enter relay 2 time delay setup
On2	On 2	Set relay 2 On time delay
OFF2	Off 2	Set relay 2 Off time delay
brEH	Break	Set RTD/TC input break relay behavior
brH1	Relay 1 Break	Set relay 1 input break relay behavior
OFF	Off	Set relay to non-alarm condition at break
On	On	Set relay to alarm condition at break
brH2	Relay 2 Break	Set relay 2 input break relay behavior
RoUt	Analog output	Enter the <i>Analog output</i> menu
ScAL	Scale	Enter the Scale menu
d1S1	Display 1	Program display 1 value
oUt1	Output 1	Program output 1 value (e.g. 4 mA)
d1S2	Display 2	Program display 2 value
oUt2	Output 2	Program output 2 value (e.g. 20 mA)
SEbr	Sensor break	Program TC or RTD sensor break value for analog out
PASS	Password	Enter the <i>Password</i> menu
UnLc	Unlocked	Program password to lock meter
LoCd	Locked	Enter password to unlock meter
9999 - 1999 oPEn	Flashing display	Overrange condition Underrange condition Open TC or RTD sensor

8.4 Main Menu

The main menu consists of the most commonly used functions: *Setup* and *Password*.

- Press **Menu** button to enter Programming Mode then press **Up** arrow button to scroll main menu.

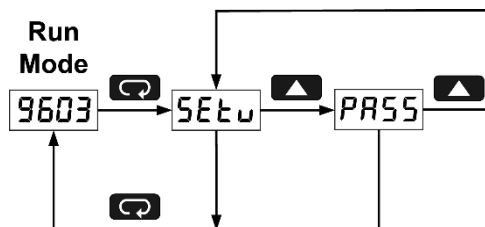

- Press **Menu**, at any time, to exit and return to Run Mode. Changes made to settings prior to pressing **Enter/Ack** are not saved.
- Changes to the settings are saved to memory only after pressing **Enter/Ack**.

Process & Temperature Meter

- The display moves to the next menu every time a setting is accepted by pressing **Enter/Ack**.

8.5 Setting Numeric Values

The numeric values are set using the **Right** and **Up** arrow buttons. Press **Right** arrow to select next digit and **Up** arrow to increment digit value.

The digit being changed is displayed brighter than the rest.

Press the **Enter/Ack** button, at any time, to accept a setting or **Menu** button to exit without saving changes.

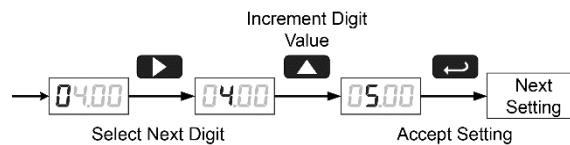

The decimal point is set using the **Up** arrow button in the *Setup-decimal point* menu.

8.6 Setting Up the Meter (SEtU)

The *Setup* menu is used to select:

1. Input signal the meter will accept
2. Decimal point position for process inputs
3. Units (°F or °C) for temperature inputs
4. Relay operation
5. 4-20 mA analog output setup

Press the **Enter/Ack** button to access any menu or press **Up** arrow button to scroll through choices. Press the **Menu** button to exit at any time.

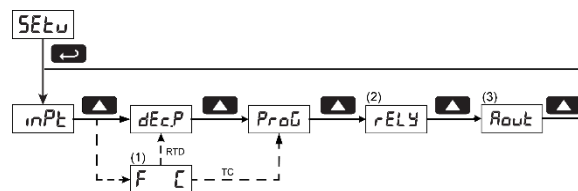

1. Selecting RTD or TC mode from the Input menu will include the Fahrenheit/Celsius menu in the setup menu structure. RTD will allow the selection of a decimal point location after this menu and TC has a fixed decimal point location and will not allow the selection of a decimal point location.
2. Analog Output menu is available if selected in the Advanced Features menu. 4-20 mA output option board is installed and set up at the factory.

Process & Temperature Meter

8.6.1 Setting the Input Signal (inPt)

Enter the *Input* menu to set up the meter to display current (4-20), voltage (0-10), thermocouple (tC), or RTD (rtd) inputs.

The voltage input is capable of accepting any signal from -10 to +10 VDC. Select voltage input to accept

0-5, 1-5, 0-10, or ±10 VDC signals.

The current input is capable of accepting any signal from -20 to 20 mA. Select current input to accept 0-20 or 4-20 mA signals.

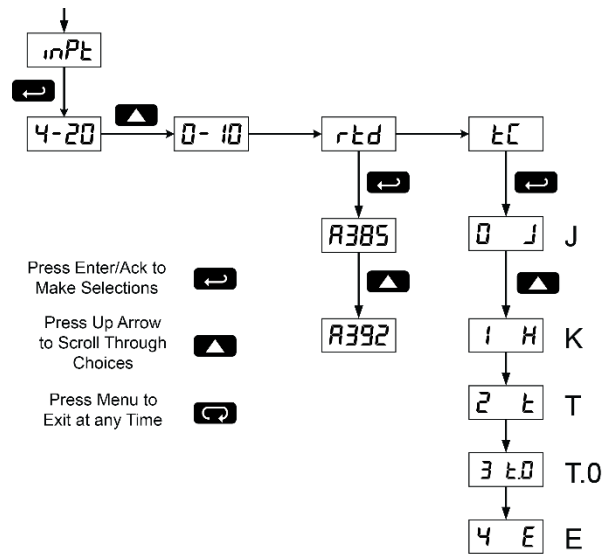

If RTD is selected, the display shows *R385* or *R392*. Select the coefficient to match the RTD sensor, either 0.00385 (*R385_* European curve) or 0.00392 (*R392_* American curve). The display then shows the decimal point menu, *dEc_P*. Select the decimal point resolution as shown on page 25.

If TC is selected, scroll through the thermocouple types and select the type matching the TC sensor. The input signal must be connected to the appropriate input terminals and the RTD/TC selector switch must be set, see *Figure 12. Thermocouple Input Connections* on page 18.



For thermocouple inputs, allow at least 30 minutes warm-up time for meter to reach specified accuracy.

8.6.2 Setting the Decimal Point (dc_Pt)

The decimal point for process inputs may be set with up to three decimal places or with no decimal point at all. The decimal point for RTD inputs may be set with 1 decimal place or none.

The decimal point for thermocouple inputs is fixed per input selection.

Pressing the **Up** arrow moves the decimal point one place to the right until no decimal point is displayed, it then moves to the leftmost position.

Process & Temperature Meter

8.6.3 Setting the Temperature Scale (F C)

Meters with a thermocouple or RTD input can be set to display temperature in degrees Fahrenheit or Celsius.

Press **Up** arrow to change selection.

Press **Enter/Ack** to accept.

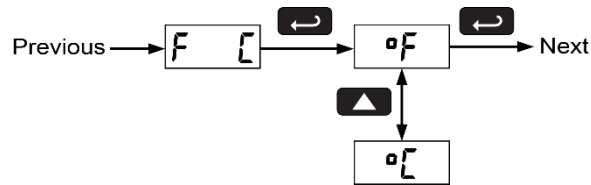

8.7 Programming the Meter (Prog)

The meter may either be scaled (ScAL) without applying an input or calibrated (CaI) by applying an input. The meter comes factory calibrated to NIST standards, so for initial setup, it is recommended to use the (ScAL) function.

The Program menu contains the Scale (ScAL) and the Calibrate (CaI) menus.

Process inputs may be scaled or calibrated to any display within the range of the meter.

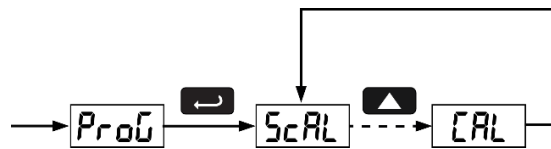

8.7.1 Scaling the Meter (ScAL)

The process inputs (4-20 mA and ±10 VDC) can be scaled to display the process in engineering units. A signal source is not needed to scale the meter; simply program the inputs and corresponding display values.

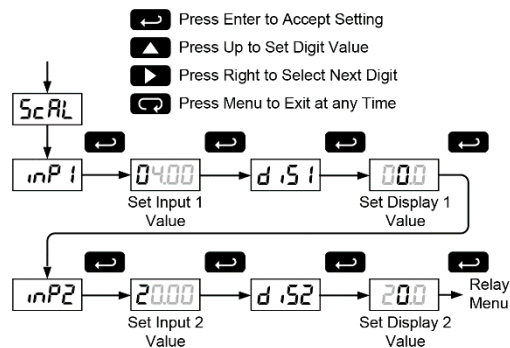

For instructions on how to program numeric values see Setting Numeric Values, page 24.



The Scale menu is not available for temperature inputs.

Error Message (Err)

An error message indicates that the calibration or scaling process was not successful.

After the error message is displayed, the meter reverts to input 1, allowing the appropriate input signals to be applied.

The error message might be caused by any of the following conditions:

1. Input signal is not connected to the proper terminals or it is connected backwards.
2. Wrong signal selection in *Setup* menu.
3. Minimum input span requirements not maintained.
4. Input 1 signal inadvertently applied to calibrate input 2.

Minimum Input Span

The minimum input span is the minimum difference between input 1 and input 2 signals required to complete the calibration or scaling of the meter.

Input range	Input 1 & input 2 span
4-20 mA	0.40 mA
±10 VDC	0.20 VDC
TC	100°F (56°C)
RTD	50°F (28°C)

8.7.2 Calibrating the Meter (CAL)

The meter can be calibrated to display the process in engineering units by applying the appropriate input signals and following the calibration procedure.

The use of a calibrated signal source is required to calibrate the meter.

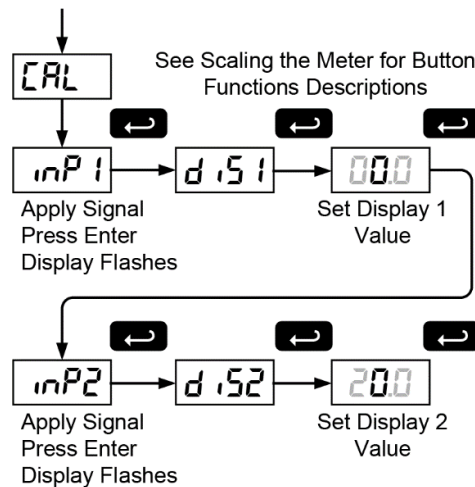

Process & Temperature Meter**8.7.3 Recalibrating Temperature Inputs (CAL)**

Remember, the meter is **calibrated** at the factory prior to shipment. Recalibration is recommended at least every twelve months.

The *Calibration* (CAL) menu is used to **recalibrate** the thermocouple and RTD inputs.



Allow at least 30 minutes warm-up time before performing recalibration procedure to ensure specified accuracy.

Recommended Calibration Points

To recalibrate the meter, it is recommended to use the Fahrenheit scale; this will give a greater degree of accuracy to the calibration. The scale can be changed to the Celsius scale after calibration is completed. The meter will display temperature accurately in any scale. The following table shows the recommended low and high calibration points for all types.

Type of input	Input 1 (Low)	Input 2 (High)	Check (Middle)
Type J T/C	32°F	1182°F	600°F
Type K T/C	32°F	1893°F	960°F
Type T T/C	32°F	693°F	360°F
Type T T/C	32.0°F	693.0°F	360.0°F
Type E T/C	32°F	1652°F	840°F
100 Ω RTD (0.00385)	32°F 100Ω	1148°F 320.12Ω	590°F 215.61Ω
100 Ω RTD (0.00392)	32°F 100Ω	1127°F 320.89Ω	580°F 215.87Ω

Recalibration Procedure for Temperature Inputs

1. Connect signal to the meter using the appropriate wire (e.g. type J thermocouple wire to recalibrate type J input), see page 18.
2. Set up the meter to accept the selected input (e.g. type J T/C), see page 25.
3. Set up the meter to display temperature in degrees Fahrenheit, see page 26.
4. Apply signal corresponding to input 1 (32°F) and program display 1 to 32, see page 27.
5. Apply signal corresponding to input 2 (1182°F for type J) and program display 2 accordingly, see page 27.
6. After the meter accepts input 2, the display flashes the message \llcorner that indicates the meter is sensing the cold junction reference. This completes the recalibration procedure for the selected input.

8.7.4 Recalibrating Process Inputs (i CAL)

The *Internal Calibration (i CAL)* menu, located in the Advanced features menu, is used to recalibrate the current and voltage inputs. Recalibration is recommended at least every twelve months.

Refer to *Internal Calibration (i CAL)*, page 53 for instructions.

8.7.5 Setting the Relay Operation (rELY)

This menu allows you to set up the operation of the relays:

1. Relay action (ACT)
 - a. Automatic reset only (non-latching)
 - b. Automatic + manual reset at any time (non-latching)
 - c. Latching (manual reset only)
 - d. Latching with Clear (manual reset only after alarm condition has cleared)
 - e. Pump alternation control (automatic reset only)
 - f. Off (relay and status LED disabled)
2. Set point
3. Reset point
4. Fail-safe operation
 - a. On (enabled)
 - b. Off (disabled)
5. Time delay
 - a. On delay (0-199 seconds)
 - b. Off delay (0-199 seconds)
6. Break Condition Behavior
 - a. Off (non-alarm condition)
 - b. On (alarm condition)



Refer to page 22 for a description of *Display Functions and Messages*

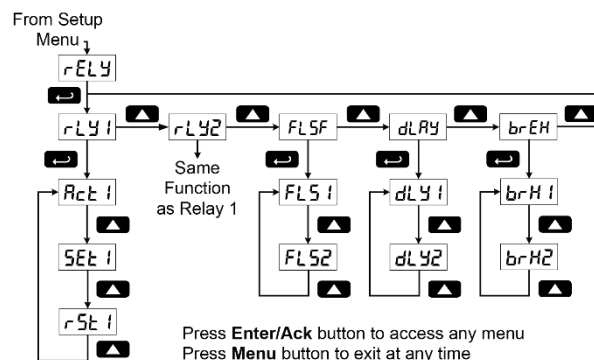

Setting the Relay Action

The relays' *Action* menu allows the user to set up the operation of the relays. The relays may be set up for any of the following modes of operation:

1. Automatic reset (non-latching)
2. Automatic + manual reset at any time (non-latching)
3. Latching (manual reset only, at any time)
4. Latching with Clear (manual reset only after alarm condition has cleared)
5. Pump alternation control (automatic reset only)
6. Off (relay and status LED disabled)

The following graphic shows relay 1 action setup; relay 2 is set up in a similar fashion.

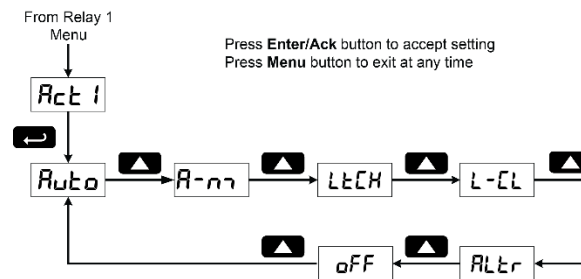

Programming Set and Reset Points

High alarm indication: program set point above reset point.

Low alarm indication: program set point below reset point.

The deadband is determined by the difference between set and reset points. Minimum deadband is one display count. If set and reset points are programmed the same, relay will reset one count below set point.



Quick Set Points: Press **Up** arrow and **Menu** at the same time to access set/reset points quickly.

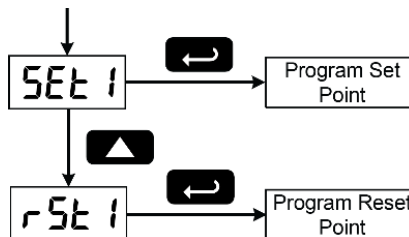

Setting Fail-Safe Operation

The fail-safe operation is set independently for each relay. Select **on** to enable or select **oFF** to disable fail-safe operation.

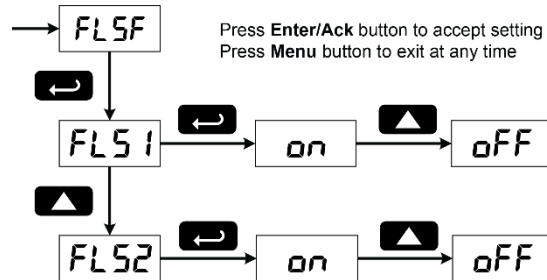

Programming Time Delay

The *On* and *Off* time delays may be programmed for each relay between 0 and 199 seconds. The relays will transfer only after the condition has been maintained for the corresponding time delay.

The *On* time delay is associated with the set point.

The *Off* time delay is associated with the reset point.

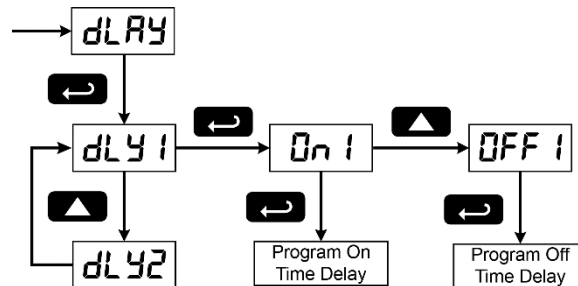

Setting Sensor Break Condition

The sensor break relay condition may be programmed for each relay as *On* (alarm) or *Off* (non-alarm). The relays will enter these states when a sensor break is detected for RTD or thermocouple inputs. These settings have no effect when current or voltage inputs are selected.

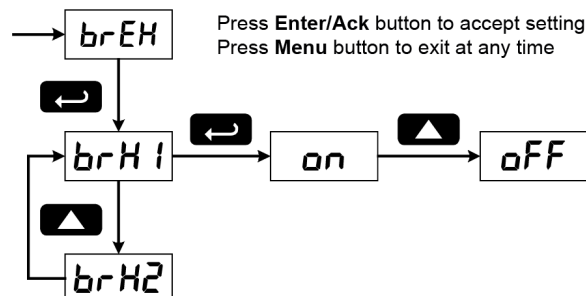

Sensor Break Operation

The following graphs illustrate the operation of how the meter reacts when a sensor break is detected.

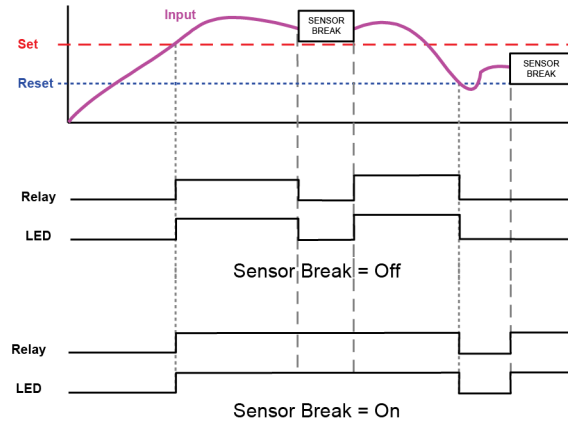

8.7.6 Relay and Alarm Operation

The following graphs illustrate the operation of the relays, status LEDs, and ACK button.

High Alarm Operation (Set > Reset)

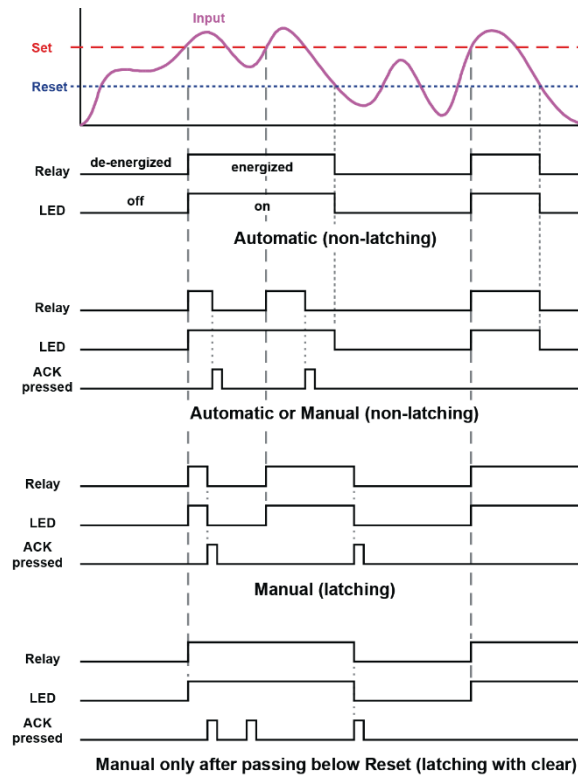

For Manual reset mode, ACK can be pressed anytime to turn “off” relay. For relay to turn back “on”, signal must go below set point, and then go above it.

Process & Temperature Meter

Low Alarm Operation (Set < Reset)

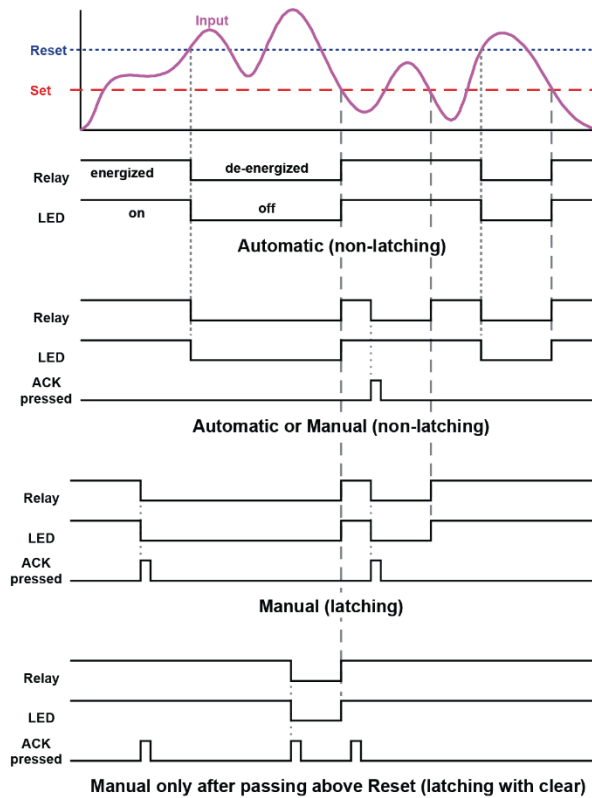

For Manual reset mode, ACK can be pressed anytime to turn “off” relay. For relay to turn back “on”, signal must go above set point, and then go below it.

Time Delay Operation

The following graphs show the operation of the time delay function.

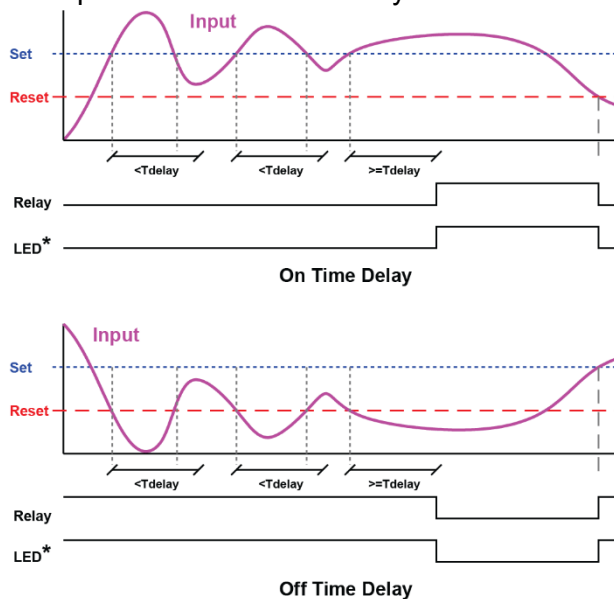

Process & Temperature Meter

If the signal crosses the set point, the *On* time delay timer starts and the relay trips when the time delay has elapsed. If the signal drops below the set point (high alarm) before the time delay has elapsed, the *On* time delay timer resets and the relay does not change state. The same principle applies to the *Off* time delay.



Note: The LED is not affected by Time Delay when “*Automatic or Manual*” reset mode is selected. Rather the LED follows the set and reset points.

High Alarm with Fail-Safe Operation (Set > Reset)

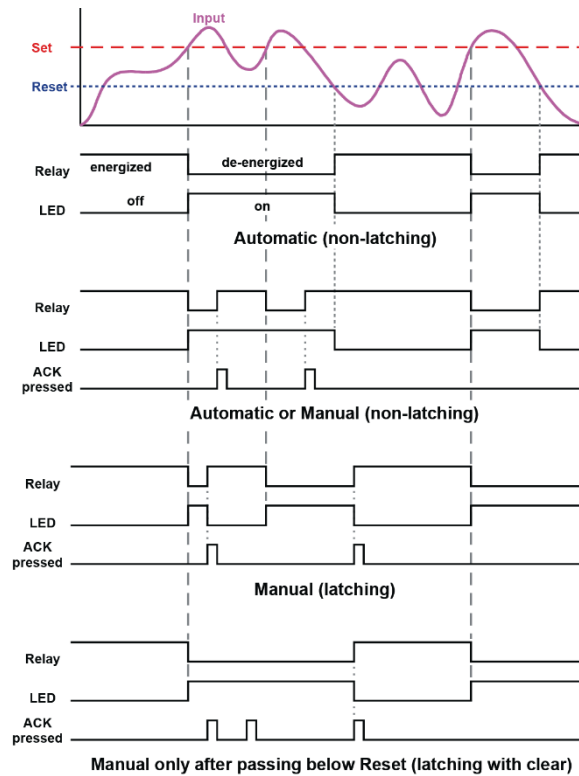

Error! Reference source not found.

Low Alarm with Fail-Safe Operation (Set < Reset)

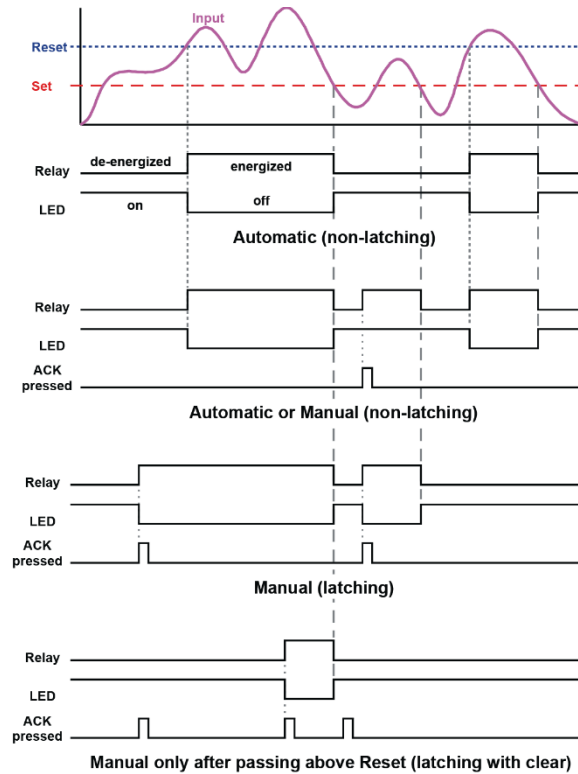

Error! Reference source not found.

Process & Temperature Meter

Pump Controller with Dual-Pump Alternation

The 330R2 can be used as a low-cost pump controller when combined with a continuous level transmitter. One of the most common pump control application is shown below: controlling and alternating two pumps. The goal is to control the level between 1000 and 6000 gallons. The main pump turns on when the level reaches 6000 gallons and pumps down to 1000 gallons and then shuts the pump off. The next cycle, the backup pump turns on at 6000 gallons and shuts off at 1000 gallons. If at any time the active pump can't keep the level below 7000 gallons, the other pump would come on also.

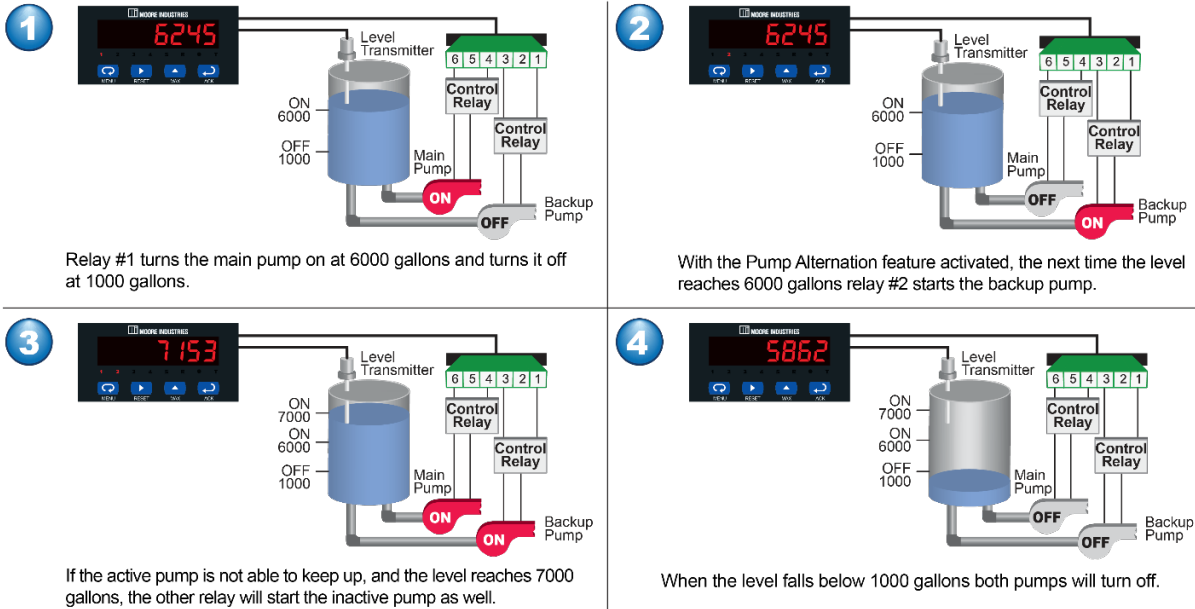

Pump Alternation Control Operation

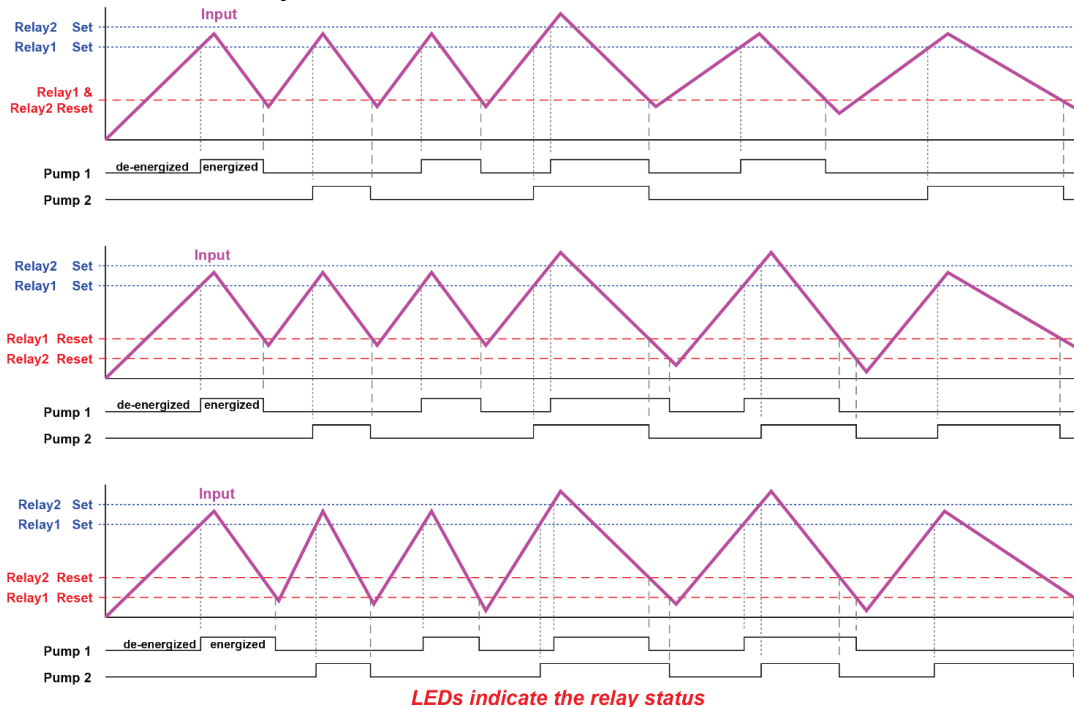

8.7.7 Scaling the 4-20 mA Analog Output (Aout)

The 4-20 mA analog output can be scaled to provide a 4-20 mA signal for any display range selected. No equipment is needed to scale the analog output; simply program the display values to the corresponding mA output signal.

The *Analog Output* menu appears in the *Setup* menu only on meters that are equipped with a 4-20 mA output. This menu is enabled or disabled at the factory via the *Advanced Features* menu. For more information on the *Advanced Features Menu*, see page **Error! Bookmark not defined.**

The *Analog Output* menu is used to program:

1. 4-20 mA output based on display values
2. Sensor break value in mA

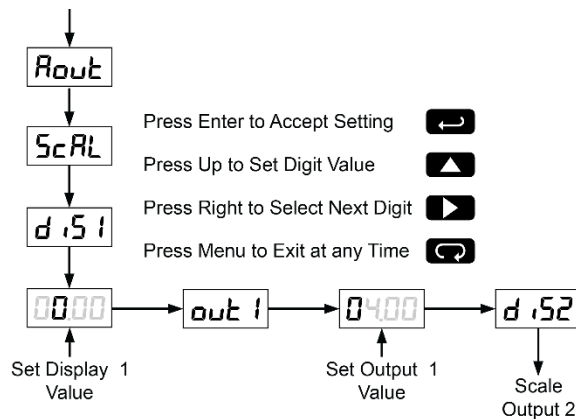

For instructions on how to program numeric values see *Setting Numeric Values*, page 24

8.7.8 Program the Sensor Break Output Value (SEbr)

The sensor break value corresponds to the output signal generated when the meter detects a sensor break for thermocouple and RTD inputs.

For example if there is an open thermocouple, the meter displays the message “**oPEr**” and the analog output goes to the programmed sensor break value (e.g. 3.00 mA).

The sensor break value can be programmed from 0.00 to 23.99.

The typical output signal range is 1.00 to 23.00 mA (e.g. If sensor break value is programmed to 0.00, the actual output will not be greater than 1.00 mA).

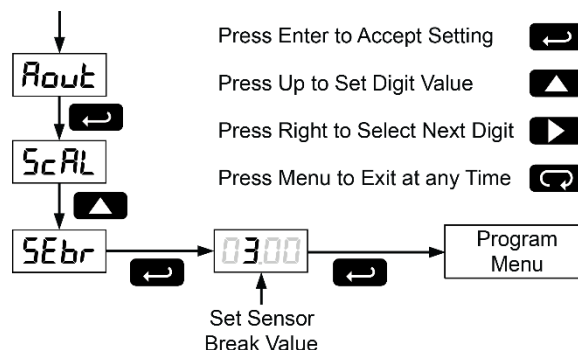

8.7.9 Analog Output when Display is Out of Range

The analog output reflects the display out of range conditions as follows:

Input Condition	Display	Analog Output
Underrange	Flashing -1999	3.00 mA
Overrange	Flashing 9999	21.00 mA
Open TC or RTD	Flashing σPE_n	Sensor break value

8.8 Setting Up the Password (PASS)

The *Password* menu is used to program a four-digit password to prevent unauthorized changes to the programmed parameter settings.

8.8.1 Locking the Meter

Enter the *Password* menu and program a four-digit password.

For instructions on how to program numeric values see *Setting Numeric Values*, page 24.

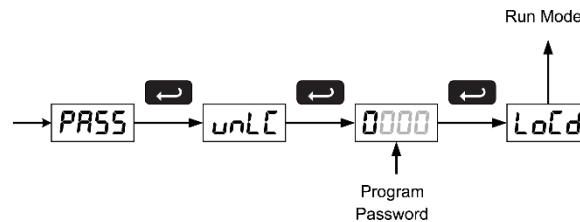

Record the password for future reference. If appropriate, it may be recorded in the space provided.

Model:	
Serial Number:	
Password:	_ _ _ _

8.8.2 Unlocking the Meter

If the meter is password protected, the correct password must be entered in order to make changes to the parameter settings.

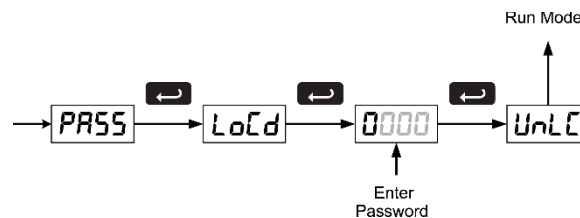

Process & Temperature Meter

Entering the correct four-digit number sets the password to 0000, disabling the protection.

Changes to the programmed parameter settings are allowed only with the password set to 0000.

If the password entered is incorrect, the meter displays *LoCd* (Locked) for about two seconds, then it returns to Run Mode. To try again, press **Enter/Ack** while the *Locked* message is displayed.

Forgot the Password?

The password may be disabled by the following procedure:

1. Note display reading prior to pressing the Menu button. Ignore decimal point and sign.
2. Access the *Password* menu, add 2 to the noted reading and enter that number as the password (e.g. display reading = -1.23, password = 0125)

8.9 Advanced Features Menu

To simplify the setup process, functions not needed for most applications are located in the *Advanced Features* menu.

Press the **Right** arrow and **Menu** button simultaneously or hold the Menu button for approximately 3 seconds to access the *Advanced Features Menu* of the meter.

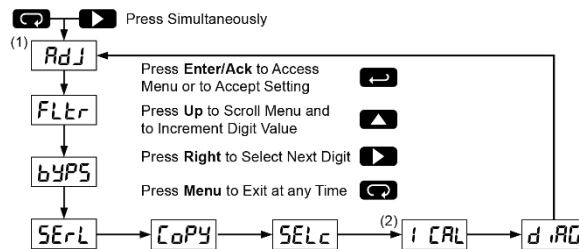

1. Available for temperature inputs only
2. Available for process inputs only

8.9.1 Advanced Features Menu & Display Messages

Display Functions and Messages		
Display	Parameter	Action/Setting
RdJ	Adjust	Set offset adjustment for temperature, not available for process inputs
FLtR	Filter	Set noise filter value
SElc	Select	Enter the Select menu (function, cutoff, out)
FUnC	Function	Select linear or square root function
Linr	Linear	Set meter for linear function
SqrE	Square root	Set meter for square root extraction
cUeF	Cutoff	Set low-flow cutoff
oUt	Output	Set meter for either relay or analog output (factory set only; only included in certain models)
RoUt	Analog output	Set meter for analog output option
rELY	Relay	Set meter for relay
RoUt	Analog output	Enable or disable analog output

Process & Temperature Meter

Display Functions and Messages		
Display	Parameter	Action/Setting
		(factory set only; only included in certain models)
YES	Yes	Enable analog output
no	No	Disable analog output
INTY	Intensity	Select display intensity
ICAL	Initial calibration	Enter initial calibration for process inputs
CURR	Current	Calibrating current input
ILo	I low	Calibrate low current input
IHi	I high	Calibrate high current input
volt	Volt	Calibrating voltage input
vLo	V low	Calibrate low voltage input
vHi	V high	Calibrate high voltage input
diag	Diagnostics	Display parameter settings
LED	LED	Test display
CJC	CJC	Display cold junction compensation voltage
CFG	CFG	Display meter configuration
PTS	Points	Display calibration points for process inputs
REL	Relays	Display relay settings
ADJ	Analog output	Display analog output settings
Goff	Gain/offset	Display gain and offset for process inputs
Info	Information	Display software version and S/N information

8.9.2 Offset Adjustment (ADJ)

This parameter allows the user to select an offset adjustment to the temperature being displayed. Offset adjustment values can be either positive or negative and can be any number within $\pm 19.9^\circ$. The offset adjustment value is programmed through the *Adjust* menu.

The offset adjustment feature can be useful to compensate for errors due to thermocouple junctions or excessive lead wire resistance in RTDs.

The offset adjustment value is automatically reset to zero whenever the type of temperature sensor is changed (*i.e.* Thermocouple type or RTD curve).

Celsius/Fahrenheit conversion of the offset adjustment value is automatic, see note 2 below for important limitations.

	<p>Notes:</p> <ol style="list-style-type: none"> Offset adjustment is available only when TC or RTD input is selected. If adjustment value is greater than 11°C and the temperature scale is changed to Fahrenheit, the maximum applied adjustment will be 19.9°F.
---	---

Process & Temperature Meter

8.9.3 Noise Filter (FLTR)

Most applications do not require changing this parameter. It is intended to help attain a steady display with an unsteady (noisy) input signal.

The field selectable noise filter averages any minor or quick changes in the input signal and displays the reading with greater stability.

Increasing the filter value will help stabilize the display, however this will reduce the display response to changes on the input signal.

The filter level may be set anywhere from 2 to 199.

Setting filter value to zero disables filter function, and bypass setting becomes irrelevant.

8.9.4 Noise Filter Bypass (bYP5)

The meter can be programmed to filter small input changes, but allow larger input changes to be displayed immediately, by setting the bypass value accordingly.

If the input signal goes beyond the bypass value, it will be displayed immediately with no averaging done on it.

The noise filter bypass value may be set anywhere from 0.2 to 99.9. It corresponds to percentage of full scale for process inputs and to degrees Fahrenheit for temperature inputs.

Increasing the bypass value may slow down the display response to changes on the input signal.

8.9.5 Select Menu (SELC)

The *Select* menu is used to select linear or square root function, display intensity, and low-flow cutoff. Selection for relay or analog output is a factory setting depending on the option installed.



- Output options are installed and set up at the factory.
- Changing the output selection will cause erroneous operation.

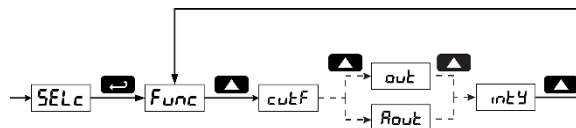

Note: Depending on meter model, the *Select* menu will display either *out* or *Aout*. In either case, the output selection menu is for factory use only. Do not attempt to change output selection.

8.9.6 Linear or Square Root Function (L inr or 59rE)

Meters are set up at the factory for linear function. The linear function provides a display that is linear with respect to the input signal.

The square root function is used to linearize the signal from a differential pressure transmitter and display flow rate in engineering units.

Process & Temperature Meter

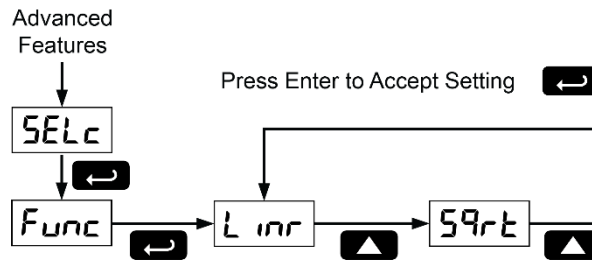

8.9.7 Low-Flow Cutoff (cutF)

The low-flow cutoff feature allows the meter to be programmed so that the often-unsteady output from a differential pressure transmitter, at low flow rates, always displays zero on the meter.

The cutoff value may be programmed from 0 to 9999. Below the cutoff value, the meter will display zero. Programming the cutoff value to zero disables the cutoff.

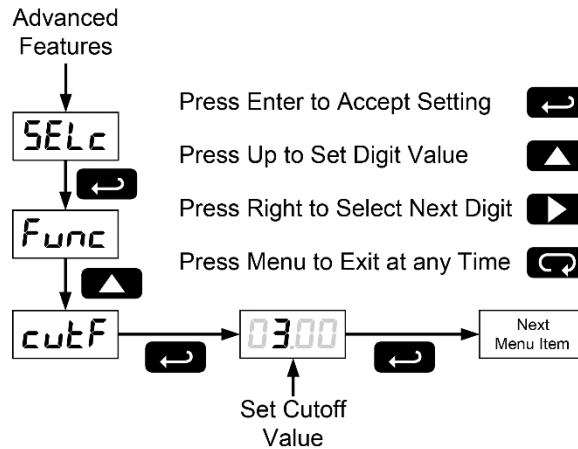

8.9.8 Display Intensity (intY)

The Display Intensity function allows the selection of eight levels of intensity for various lighting conditions.

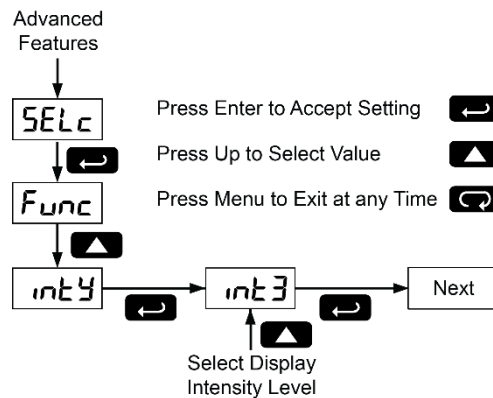

9 MeterView Software



Note: The 330R2 meter is not powered from USB connection and requires external power to be programmed. The easiest and quickest way to program your meter is to use the FREE MeterView software and the 330-R2C-26 USB adapter.

9.1 Remote Programming

MeterView software allows all setup parameters to be programmed remotely from a PC and saved to a file for reporting or programming other meters. A USB to serial adapter, model 330-R2C-26 (sold separately) is required to use MeterView Pro software.

9.2 330-R2C-26 Meter to USB Serial Adapter



Process & Temperature Meter

Description

The 330-R2C-26 Meter to USB Serial Adapter allows for direct connection of a 330R2 meter to the USB port of a PC. It is intended only for programming the meter.

Figure 18. 330-R2C-26 USB Adapter Connections

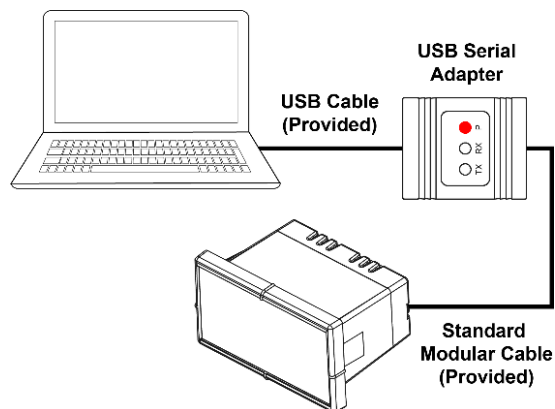

9.3 MeterView Installation

1. Go to www.miinet.com/software.html
2. Read instructions & copy serial # of desired MeterView version
3. Download Installation file to computer
4. Double-click installation file to open it
5. Double-click **Setup.exe** to begin installation
6. Follow on-screen instructions

9.4 Running MeterView the First Time

The first time MeterView is run it is necessary to set up the serial communication settings of the program. Select the communication port and the baud rate of the meter(s) connected.

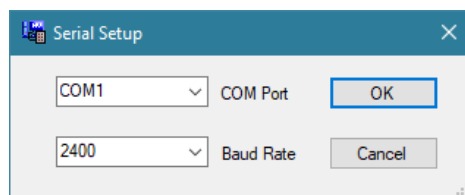

Note: The selected baud rate in MeterView and the meter(s) baud rate must be the same. Otherwise a communication error will occur.

Process & Temperature Meter

9.4.1 Enable Meter and Select Meter Address

The actual meter address is set up at the meter using the front panel buttons. The location where a meter is displayed is selected on MeterView Main window.

To enable or select a meter with a different serial address:

1. Right-click on the screen location of meter.
2. Click on **Enabled**, if meter is not yet enabled.
3. Click on **Change Address**.
4. Select meter address to display in this location.

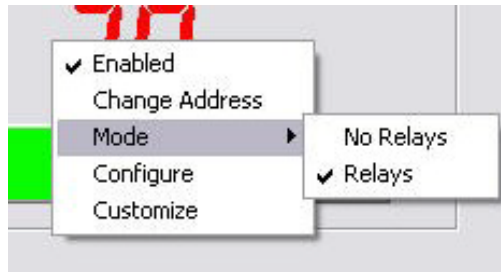

9.5 MeterView Main Window

The main MeterView window shows the present reading(s), relays/alarm status, tag number(s) and selected engineering units, along with other information for each meter. The graphic below indicates the different parts of the main MeterView window.

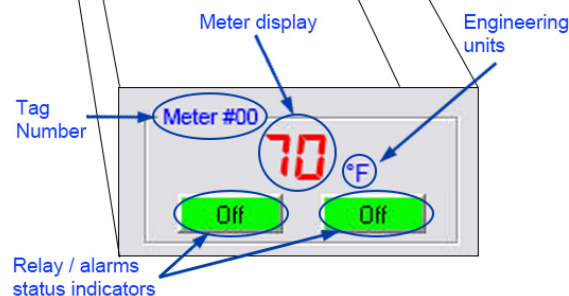
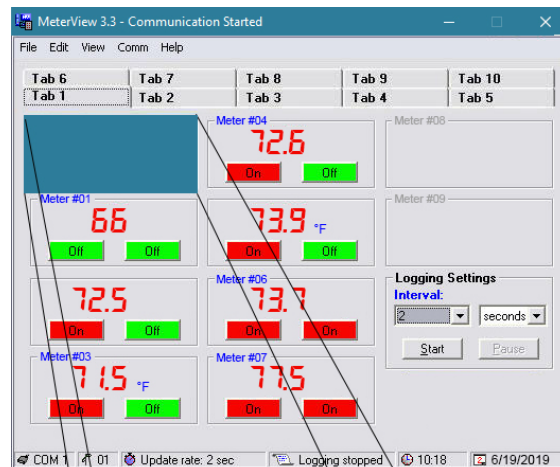

Process & Temperature Meter

9.5.1 Main Window Menus

The MeterView main window contains the following menus:

- File menu
- Edit menu
- View menu
- Comm Menu
- Help Menu

File Menu

The following options are available from this menu:

1. **Exit** to close the MeterView program.

Edit Menu

The following options are available from this menu:

1. **Serial Settings** to edit the serial communication settings.
2. **Number of Meters** to automatically populate the Main Window with a single meter, 10 meters, or 100 meters.

View Menu

The following options are available from this menu:

1. **Event Log** to view the MeterView event log window where all internal program events and errors are logged.
2. **Show Relay Alerts** select whether or not MeterView should alert the user of a change in the relay status (ON → OFF or vice versa) with a pop-up message.

Comm Menu

The following options are available from this menu:

1. **Stop** to halt the automatic meter scanning. This allows quicker access to menu items, functions, and windows.
2. **Start** to resume the automatic meter scanning.

Help Menu

The following options are available from this menu:

1. **www.miinet.com**
2. **About Meterview 3.3** for version number and build information.

Process & Temperature Meter

Right Click Menu

By right clicking on a meter on the screen a menu will appear with the following options:

Menu Item	Function/Submenus
Enabled	Enable or disable a meter on the screen
Change Address	Change a meter's serial address in MeterView
Mode	Show relays
Configure	Access the configuration window for a meter
Customize	Customize how a meter looks on the screen

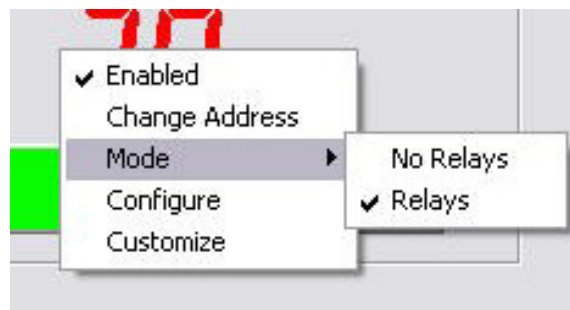

Note:



- Accessing menus or other windows could disrupt communication with the meter(s).
- Use left mouse button or tab key on the keyboard to navigate within a window.
- Parameters not available within a window appear grayed-out.
- An arrow next to a box indicates a drop-down menu. Click on arrow to display the drop-down menu.

9.6 Configuration Window

Click on **Configure** in the right click menu to open a meter's configuration window. The following settings can be programmed from this window:

1. Input type (4-20 mA, 0-10 V, RTD, or TC).
2. Decimal point for process inputs (dd.dd).
3. Units (F or C) and sensor type for temperature inputs.
4. Values for scaling process inputs, values for scaling analog output, Password, Adjust (temperature only), Filter, Bypass, Cutoff (process inputs only), Transmit Delay, Function type, and Cut-off.
5. Relay settings.
6. After the last change has been made, click the **Write to Meter** button or press Enter on the keyboard to send the new settings to the meter, or click on **Exit** to abandon changes. Before sending the new settings, MeterView will ask to confirm that the meter's current settings should be overwritten. Click **Yes** to overwrite the settings, or **No** to abort the operation and return to the configuration window.

The configuration window contains the following menus:

- File menu
- Tools menu
- Password menu



Note: Accessing menus or other windows could disrupt communication with the other meter(s).

9.6.1 File Menu

The following options are available from the File menu:

1. **Save Configuration** to save the present settings to a file.
2. **Load Configuration** to load settings from a file.
3. **Export to HTML** to save the present settings to a HTML file.
4. **Import from HTML** to load settings from a HTML file.
5. **Print Configuration**

9.6.2 Tools Menu

The following option is available from the Tools menu:

1. **Load Defaults** to load the factory default settings.



It is recommended to save a configuration file before changing any setting and before any calibration operation.

Process & Temperature Meter

9.6.3 Password Menu

The following options are available from the Password menu:

1. **Lock Meter** to lock the meter and prevent unauthorized changes.
2. **Unlock Meter** to unlock the meter and allow changes to be made.
3. **Change Password** to change the unlock password of the meter.
- 4.



The password must be a four-digit number; "0000" is the unlocked password setting.

9.6.4 Input Tab

In the configuration window, click on the **Input** tab to view the input options.

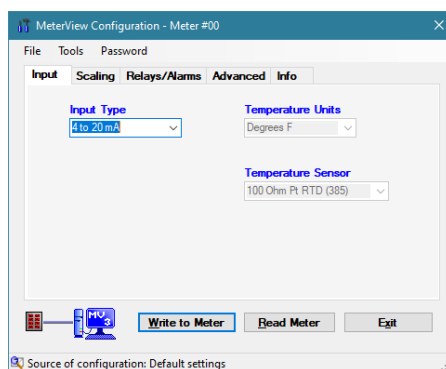

9.6.5 Set Up Input Type

Click on the arrow next to the *4 to 20 mA* box and then click on the desired input type.

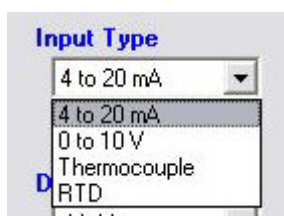

9.6.6 Set Up Decimal Point

Click on the arrow next to the *dd.dd* box and then click on the desired decimal point position. Decimal point selection is available for 4-20 mA and 0-10 V inputs only. The display scale and relay set/reset points are adjusted according to the decimal point selection.

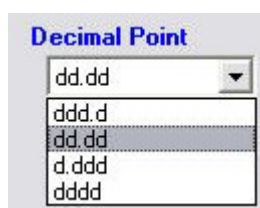

Process & Temperature Meter

9.6.7 Set Up Temperature Unit

Click on the arrow next to the *Degrees F* box and then click on the desired temperature unit. Temperature unit selection is available for Thermocouple and RTD inputs only.

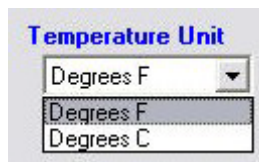

9.6.8 Set Up Temperature Sensor

Click on the arrow next to the *Type J* box and then click on the desired temperature sensor. Temperature sensor selection is available for Thermocouple and RTD inputs only.

Thermocouple Sensors

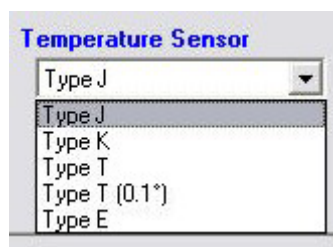

RTD Sensors

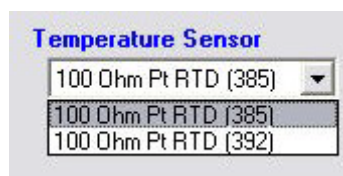

9.6.9 Scaling Tab

In the configuration window, click on the **Scaling** tab to view the scaling settings for process inputs (current and voltage).

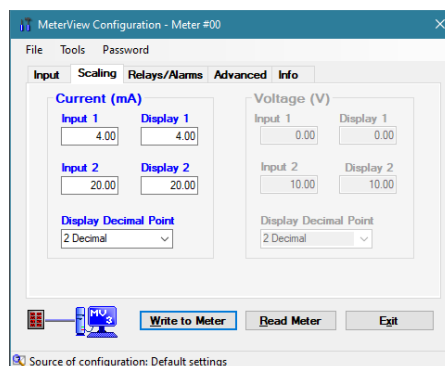

Process & Temperature Meter

9.6.10 Relays/Alarms Tab

In the configuration window, click on the **Relays/Alarms** tab to view the settings for the relays/alarms.

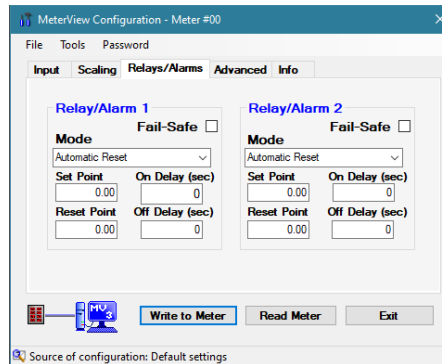

9.6.11 Advanced Tab

In the configuration window, click on the **Advanced** tab to view the advanced settings. Consult the meter manual for further details.

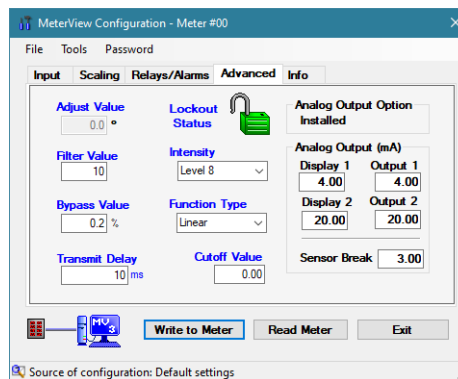

9.6.12 Info Tab

In the configuration window, click on the **info** tab to view the firmware number and version.

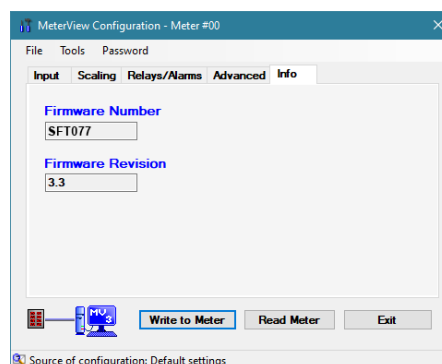

Process & Temperature Meter

9.7 Customize Window

Click on **Customize** in the right click menu to open a meter's customize window. The following settings can be programmed from this window:

1. **Tag Number** to identify a meter and optionally display it on the meter. Pre-selected special characters may be used in this field by simply dragging the desired symbol into it.
2. **Display Units** to identify the engineering units of the value being read and optionally display it on the meter. Pre-selected special characters may be used in this field by simply dragging the desired symbol into it.
3. **Display Color** to change the color of the meter display on the screen.
4. **Relay Tag** to change the text label of the Relay Status indicator(s).
5. **Relay Color** to change the color of the Relay Status indicator(s).

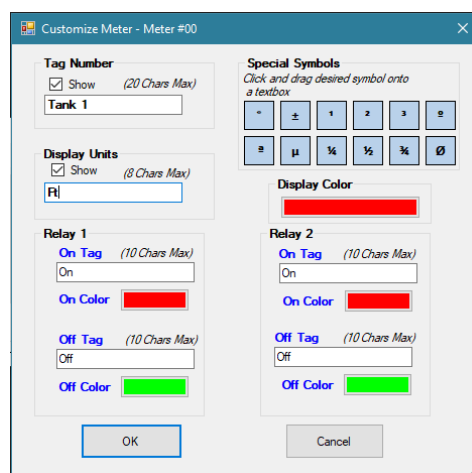

Note: These settings are **NOT** saved to the meter.

Process & Temperature Meter**9.7.1 Internal Calibration (I CAL)**

- There is no need to recalibrate the meter when first received from the factory.
- The meter is factory calibrated prior to shipment, for all input types, in milliamps, volts, and degrees respectively. The calibration equipment is certified to NIST standards.

The internal calibration allows the user to scale the meter without applying a signal. This menu is not available if the meter is set up for TC or RTD inputs.

The use of calibrated signal sources is necessary to perform the internal calibration of the meter. Check calibration of the meter at least every 12 months. Each input type must be recalibrated separately, if meter will be used with all input types.

**Note:**

- If meter is in operation and it is intended to accept only one input type (e.g. 4-20 mA), recalibration of other inputs is not necessary.
- Allow the meter to warm up for at least 30 minutes before performing the internal calibration procedure.

The *Internal calibration* menu is part of the *Advanced Features Menu*.

1. Press the Right arrow and Menu button simultaneously or hold the Menu button for approximately 3 seconds to access the *Advanced Features Menu* of the meter.
2. Press the **Up** arrow button to scroll to the *Internal calibration* menu and press **Enter/Ack**.
3. The meter displays either current (Curr) or voltage (volt), according to the meter input setup. Press **Enter/Ack** to start the calibration process.

Example for current input internal calibration:

4. The meter displays *Low* input current (I lo). Apply the low input signal and press **Enter/Ack**. The display flashes for a moment while meter is accepting the low input.
5. After the display stops flashing, a number is displayed with the leftmost digit brighter than the rest. The bright digit is the active digit that can be changed by pressing the **Up** arrow button. Press the **Right** arrow button to move to the next digit.
6. Set the display value to correspond to the input signal being calibrated.
7. The display moves to the high input calibration (I Hi). Apply the high input signal and press **Enter/Ack**.
8. Set the display for the high input calibration in the same way as it was set for the low input calibration.



For instructions on how to program numeric values see *Setting Numeric Values*, page 24.

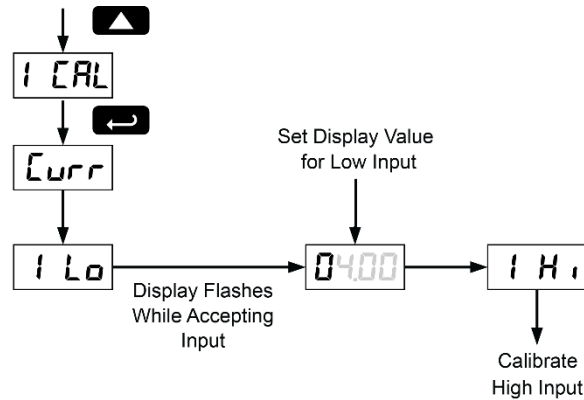

The graphic above shows the calibration of the current input. The voltage input is calibrated in a similar way.

Tips:

- Low and high input signals can be any valid values within the range of the meter.
- Observe minimum input span requirements between input 1 and input 2.
- Low input must be less than high input signal.

Error Message (Err)

An error message indicates that the calibration or scaling process was not successful.

After the error message is displayed, the meter reverts to input 1, allowing the appropriate input signals to be applied.

The error message might be caused by any of the following conditions:

1. Input signal is not connected to the proper terminals or it is connected backwards.
2. Wrong signal selection in *Setup* menu.
3. Minimum input span requirements not maintained.
4. Input 1 signal inadvertently applied to calibrate input 2.

Minimum Input Span

The minimum input span is the minimum difference between input 1 and input 2 signals required to complete the calibration or scaling of the meter.





Input range	Input 1 & input 2 span
4-20 mA	0.40 mA
±10 VDC	0.20 VDC
TC	100°F (56°C)
RTD	50°F (28°C)

10 Operation

For process inputs, the meter is capable of accepting positive and negative signals and displaying these signals in engineering units from -1999 to 9999 (e.g. a signal from -10 to +10 VDC could be displayed as -10.00 to 10.00).

The temperature inputs are displayed according to the input type and temperature units (°F or °C) selected. RTD and Type T thermocouple inputs can be displayed with either 1° or 0.1° resolution.

10.1 Front Panel Buttons Operation

Button Symbol	Description
	Press to enter or exit Programming Mode, view settings, or exit Max/Min readings Hold to enter <i>Advanced</i> features menu.
	Press to reset Max/Min readings
	Press to display Max/Min readings alternately
	Press to display Max/Min reading indefinitely while displaying Max/Min Press ACK to acknowledge relays

Process & Temperature Meter**10.2 Maximum/Minimum Readings**

The main function of the front panel buttons during operation is to display the maximum and minimum readings reached by the process or temperature inputs.

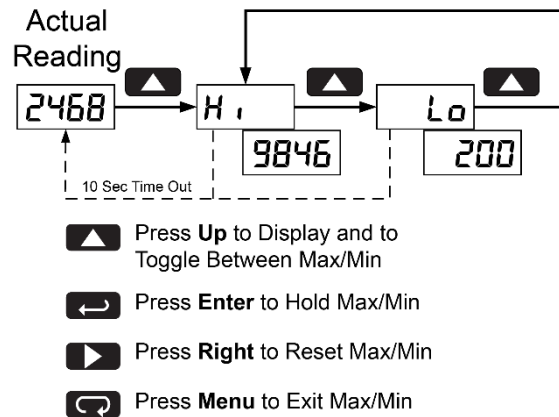

1. Press **Up** arrow/**Max** button to display maximum reading since the last reset/power-up.
2. Press **Up** arrow/**Max** again to display the minimum reading since the last reset/power-up.
3. Press **Enter/Ack** to hold Max/Min display reading, the meter will continue to track new Max/Min readings.
4. If **Enter/Ack** is not pressed, the Max/Min display reading will time out after ten seconds and the meter will return to display the actual reading.
5. Press **Right** arrow/**Reset** button to reset Max/Min while reading is being displayed. Max/Min display readings are reset to actual reading.

11 Troubleshooting

Due to the many features and functions of the meter, it's possible that the setup of the meter does not agree with what an operator expects to see. If the meter is not working as expected, refer to the *Diagnostics* menu and consult the recommendations described below.

11.1 Diagnostics Menu (d ,A9)

The *Diagnostics* menu is located in the *Advanced Features Menu*, to access *Diagnostics* menu see *Advanced Features Menu*, page **Error! Bookmark not defined.**

It provides an easy way to view the programmed parameter settings for troubleshooting purposes. Press the **Enter/Ack** button to view the settings and the **Menu** button to exit at any time.

For a description of the diagnostics messages see *Advanced Features Menu & Display Messages*, page 39.

11.1.1 Determining Software Version

To determine the software version of a meter:

1. Go to the *Diagnostics* menu (d ,A9) and press **Enter/Ack** button.
2. Press **Up** arrow/**Max** button and scroll to Information menu (I nF0).
3. Press **Enter/Ack** to access the software number (5FE), version (UER). Write down the information as it is displayed. Continue pressing **Enter/Ack** until all the information is displayed.

11.2 Reset Meter to Factory Defaults

When the parameters have been changed in a way that is difficult to determine what's happening, it might be better to start the setup process from the factory defaults.

Instructions to load factory defaults:

1. Enter the *Advanced Features Menu*. See *Advanced Features Menu*, page **Error! Bookmark not defined.**
2. Press **Up** arrow to go to *Diagnostics* menu
3. Press and hold **Right** arrow/Reset for five seconds, press **Enter/Ack** when display flashes rESEt.
Note: If **Enter/Ack** is not pressed within three seconds, display returns to *Diagnostics* menu.
4. The meter goes through an initialization sequence (same as on power-up) and loads the factory default settings.

Process & Temperature Meter

11.2.1 Factory Defaults & User Settings

The following table shows the factory setting for most of the programmable parameters on the meter. Next to the factory setting, the user may record the new setting for the particular application. MeterView software allows the saving of all meter parameters to a file for restoring meter settings, reporting, and copying settings to other meters.

Model: _____ S/N: _____ Date: _____

Parameter	Display	Default Setting	User Setting
Input type	<i>inPt</i>	4-20 mA	
Decimal point	<i>dd.dd</i>	2 places	
Programming	<i>Prog</i>		
Input 1	<i>inP1</i>	4.00 mA	
Display 1	<i>d.S1</i>	4.00	
Input 2	<i>inP2</i>	20.00 mA	
Display 2	<i>d.S2</i>	20.00	
Relay 1	<i>relY1</i>		
Action 1	<i>Act1</i>	Automatic	
Set 1	<i>SEt1</i>	7.00	
Reset 1	<i>rSEt1</i>	6.00	
Relay 2	<i>relY2</i>		
Action 2	<i>Act2</i>	Automatic	
Set 2	<i>SEt2</i>	10.00	
Reset 2	<i>rSEt2</i>	9.00	
Fail-safe	<i>FLSF</i>		
Fail-safe 1	<i>FLS1</i>	Off	
Fail-safe 2	<i>FLS2</i>	Off	
Time delay	<i>dLRY</i>		
On delay 1	<i>On1</i>	0 sec	
Off delay 1	<i>OFF1</i>	0 sec	
On delay 2	<i>On2</i>	0 sec	
Off delay 2	<i>OFF2</i>	0 sec	
Break 1	<i>brH1</i>	Off	
Break 2	<i>brH2</i>	Off	
Password	<i>PASS</i>	0000 (unlocked)	
Advanced Features	<i>nRA</i>		
Adjust	<i>Adj</i>	0.0° (temp only)	
Filter	<i>FLtr</i>	10	
Bypass	<i>bYPS</i>	0.2	

Process & Temperature Meter

Parameter	Display	Default Setting	User Setting
Baud rate	bAUsd	2400	
Function	FUnc	Linear	
Cutoff value	CUtF	0.00 (disabled)	
Output option	oUtRPAoUt	Factory set only	
Display intensity	intY	Level 8	

11.3 Troubleshooting Tips

Symptom	Check/Action
No display at all	Check power at power connector
Not able to change setup or programming, LoCd is displayed	Meter is locked, enter correct four-digit password to unlock
Meter does not respond to input change	If a Low-Flow Cutoff Value has been programmed, the meter will display zero below that point, regardless of the input – which can appear like the meter is not responding to an input change. Check to make sure the problem is not being caused by an undesired low-flow cutoff value.
Meter displays error message during calibration (Err)	Check: <ol style="list-style-type: none"> 1. Signal connections 2. Input selected in <i>Setup</i> menu 3. Minimum input span requirements
Meter displays <ul style="list-style-type: none"> • oPEr • 9999 • - 1999 • Displays negative number, not responding to RTD. 	Check: <ol style="list-style-type: none"> 1. Input selected in <i>Setup</i> menu 2. TC/RTD Switch position 3. Corresponding signal at Signal connector
Display alternates between <ol style="list-style-type: none"> 1. Hi and a number 2. Lo and a number 	Press Menu to exit Max/Min display readings.
Display response is too slow	Check filter and bypass values
Inaccurate temperature reading	Check: <ol style="list-style-type: none"> 1. Temperature units (°F or °C) 2. TC type or RTD curve selected 3. Offset adjustment 4. TC wire used 5. Calibration
If the display locks up or the meter does not respond at all	Cycle the power to restart the microprocessor.
Relay operation is reversed	Check: <ol style="list-style-type: none"> 1. Fail-safe in <i>Setup</i> menu 2. Wiring of relay contacts
Relay and status LED do not respond to signal	Check: <ol style="list-style-type: none"> 1. Relay action in <i>Setup</i> menu 2. Set and reset points
Meter not communicating with MeterView	Check: <ol style="list-style-type: none"> 1. Check 330-R2C-26 USB adapter 2. Meter and MeterView addresses and baud rates need to match

12 Quick Interface Reference Guide

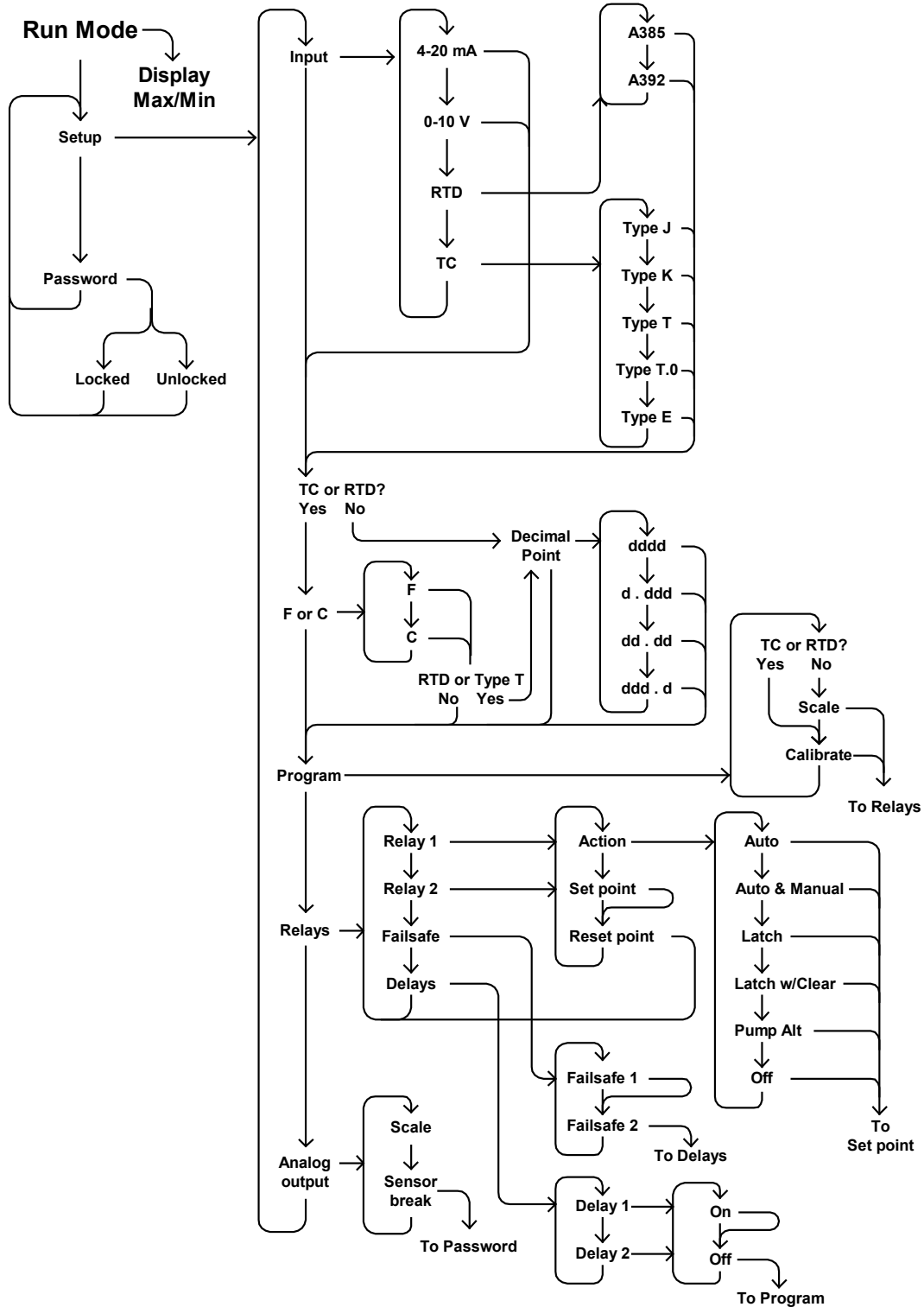

Process & Temperature Meter

Pushbutton	Function
Menu	Go to Programming Mode or leave Programming, Advanced Features, and Max/Min Modes.
Right Arrow	Move to next digit.
Up Arrow	Move to next selection or increment digit.
Enter/Ack	Accept selection/value and move to next selection.

Right Arrow & Menu simultaneously enters Advanced Features

Max/Min Mode
While in Run Mode, pressing **Up** Arrow will initiate Max/Min Mode. **Up** Arrow toggles between Max & Min displays, and **Right** Arrow resets the Max/Min to the current value. Press **Menu** or wait 10 seconds to return to Run Mode. Pressing **Enter/Ack** will disable the 10 second timeout and continuously display Max or Min.

Press **Right** arrow and **Menu** to access Advanced Features Menu

When the meter is locked, Adjust, Filter and Bypass can only display their settings, and the ICAL function is not available.

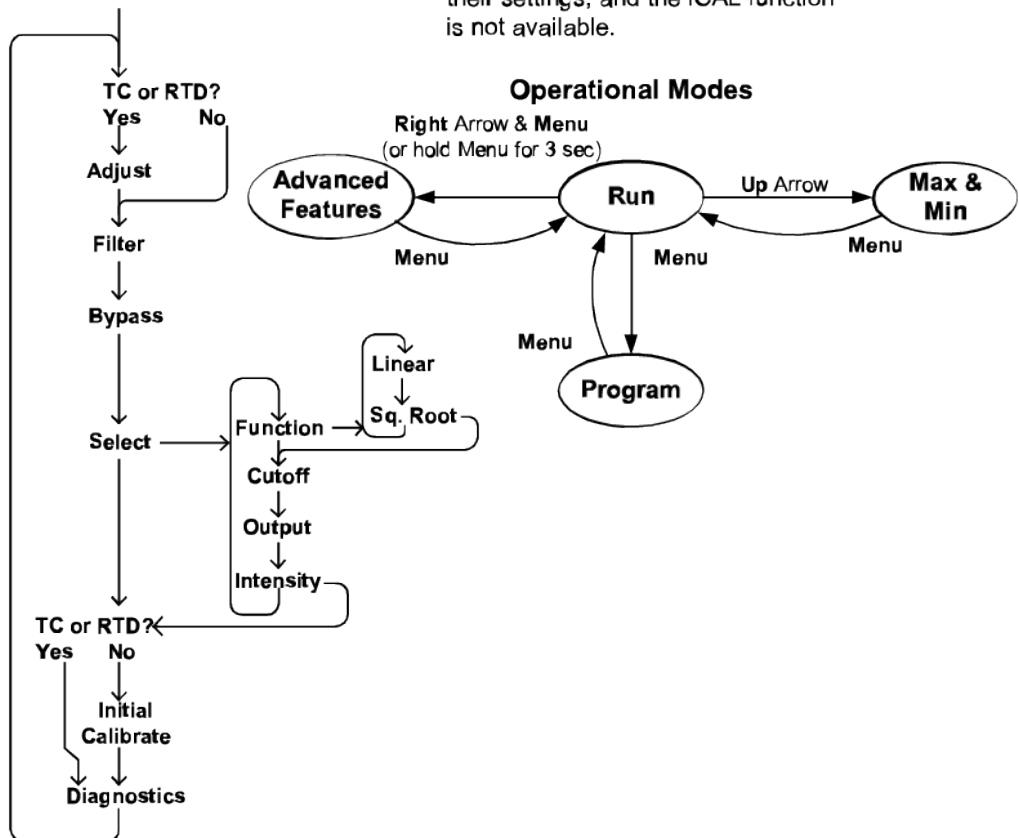

13 330R2 Warranty Disclaimer

Moore Industries ("The Company") makes no express, implied or statutory warranties (including any warranty of merchantability or of fitness for a particular purpose) with respect to any goods or services sold by the company. The company disclaims all warranties arising from any course of dealing or trade usage, and any buyer of goods or services from the company acknowledges that there are no warranties implied by custom or usage in the trade of the buyer and of the company, and that any prior dealings of the buyer with the company do not imply that the company warrants the goods or services in any way.

Any buyer of goods or services from the company agrees with the company that the sole and exclusive remedies for breach of any warranty concerning the goods or services shall be for the company, at its option, to repair or replace the goods or services or refund the purchase price. The company shall in no event be liable for any consequential or incidental damages even if the company fails in any attempt to remedy defects in the goods or services, but in such case the buyer shall be entitled to no more than a refund of all monies paid to the company by the buyer for purchase of the goods or services.

Any cause of action for breach of any warranty by the company shall be barred unless the company receives from the buyer a written notice of the alleged defect or breach within ten days from the earliest date on which the buyer could reasonably have discovered the alleged defect or breach, and no action for the breach of any warranty shall be commenced by the buyer any later than twelve months from the earliest date on which the buyer could reasonably have discovered the alleged defect or breach.

Return Policy

For a period of thirty-six (36) months from the date of shipment, and under normal conditions of use and service, Moore Industries ("The Company") will at its option replace, repair or refund the purchase price for any of its manufactured products found, upon return to the Company (transportation charges prepaid and otherwise in accordance with the return procedures established by The Company), to be defective in material or workmanship. This policy extends to the original Buyer only and not to Buyer's customers or the users of Buyer's products, unless Buyer is an engineering contractor in which case the policy shall extend to Buyer's immediate customer only. This policy shall not apply if the product has been subject to alteration, misuse, accident, neglect or improper application, installation, or operation. THE COMPANY SHALL IN NO EVENT BE LIABLE FOR ANY INCIDENTAL OR CONSEQUENTIAL DAMAGES.

To return equipment to Moore Industries for repair, follow these four steps:

1. Call Moore Industries and request a Returned Material Authorization (RMA) number.

Warranty Repair –

If you are unsure if your unit is still under warranty, we can use the unit's serial number to verify the warranty status for you over the phone. Be sure to include the RMA number on all documentation.

Non-Warranty Repair –

If your unit is out of warranty, be prepared to give us a Purchase Order number when you call. In most cases, we will be able to quote you the repair costs at that time. The repair price you are quoted will be a "Not To Exceed" price, which means that the actual repair costs may be less than the quote. Be sure to include the RMA number on all documentation.

2. Provide us with the following documentation:
 - a) A note listing the symptoms that indicate the unit needs repair.
 - b) Complete shipping information for return of the equipment after repair.
 - c) The name and phone number of the person to contact if questions arise at the factory.
3. Use sufficient packing material and carefully pack the equipment in a sturdy shipping container.
4. Ship the equipment to the Moore Industries location nearest you.

The returned equipment will be inspected and tested at the factory. A Moore Industries representative will contact the person designated on your documentation if more information is needed. The repaired equipment, or its replacement, will be returned to you in accordance with the shipping instructions furnished in your documentation.