

February 2008

Description

When integrated with the MooreHawke ROUTE-MASTER Fieldbus System for intrinsically-safe installations (RM100), the RM110 PowerTray is used to provide DC power to FOUNDATION fieldbus™ H1 interface cards that require external power (e.g., Emerson DeltaV Series 2) on the safe-area side of the fieldbus segment (Figure 1).

The 19-inch RM110 simplifies back-of-panel wiring by providing power to up to eight H1 segments. It accepts standard back-of-panel DC power and provides isolated, redundant fieldbus-conditioned power (up to 25mA per segment) to the safe-area side of ROUTE-MASTER systems.

The RM110 PowerTray is typically installed above the 19-inch ROUTE-MASTER Power Conditioner Rack (RM100) in a field cabinet. Brackets are supplied with the RM110 to affix the PowerTray to the top of the RM100 rack. However, if required, the RM110 can be installed up to 30m (98ft) from the RM100 rack, and an additional 120m (394ft) from the fieldbus H1 interface card. The RM110 provides a switchable terminator at each segment connection. When the RM100 Fieldbus System is used in dual trunk mode (see the RM100 data sheet for details), the section between the DCS and the RM110 PowerTray should not exceed 30m (98ft), and the local terminator should be turned OFF.

Figure 1. RM110 PowerTray combined with the ROUTE-MASTER RM100 Fieldbus Power Supply/Conditioner.

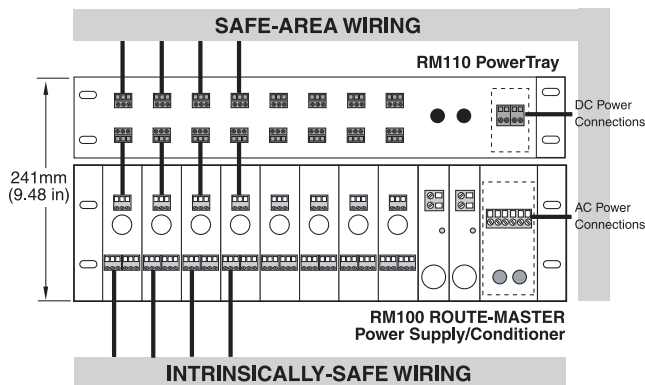

All product names are registered trademarks of their respective companies.

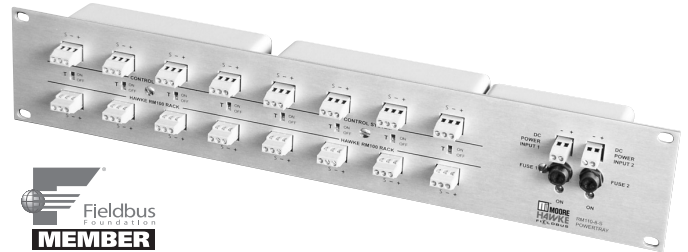

The RM100 PowerTray is typically mounted directly above the ROUTE-MASTER Power Supply/Conditioner Rack to provide conditioned power to "unpowered" H1 interfaces.

Specifications

Capacity	Up to 8 H1 segments (simplex or duplex H1 cards)
Output per Segment	15V (no load) (11V@25mA, all segments loaded)
Supply Voltage	24Vdc, ±20%
Power Loading	6W
Fault Power Dissipation	<1W (short-circuit protected per segment)
Fuse Rating	500mA
Terminals	Cage-clamp type, max. 4mm ² (12-24AWG)
Housing	19-inch rack 2U high, 80mm max. depth (no rear access required)
Ambient Conditions	Operation: -20°C to +60°C (-4°C to +140°F) Storage: -40°C to +80°C (-40°C to +176°F) Relative Humidity: 0-90%, non-condensing
EMC Compliance	To generic immunity standards EN50 082-2, Parts 1 & 2
LVD Compliance	EN60 950, EN61 010-1
Approvals	FIELDBUS Foundation Power Supply Conformance Test (Registration Pending)

Ordering Information

Description	Model Number
ROUTE-MASTER PowerTray	RM110-8-S

Certifications



CE Conformant – EMC Directive 89/336/EEC
EN 61326