

Description

Moore Industries' AC Energy Transducers continuously track the amount of power being consumed by an electric device or a system.

Dual Analog/Discrete Outputs—Each power monitor accepts an ac input from a load device such as a motor, pump, or heater. It computes the energy being consumed, and provides two separate outputs: one proportional analog and one discrete. The analog signal allows direct interface with a SCADA system for tracking instantaneous power usage. The pulse output signal drives an electronic or electromechanical counter for monitoring accumulated energy use.

All models are offered in 1, 1-1/2, 2, 2-1/2, and 3 element versions. They may be either self- or externally-powered.

Easy Installation and Maintenance—Rugged and rustproof extruded aluminum housings provide superior heat dissipation. Keyhole-slotted mounting flanges allow installation and removal simply by loosening the mounting screws.

Circuit boards are attached to the unit's front panel to allow quick access to the circuitry without removing the entire housing. The circuit boards slide smoothly out of the housing on PC board guides that run the entire length inside the unit's housing.

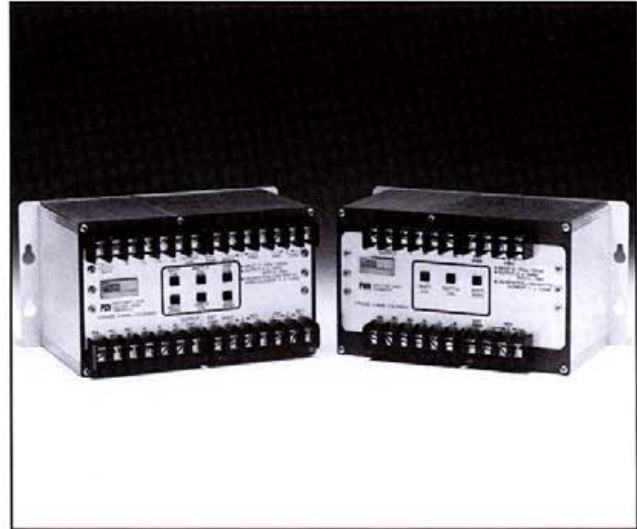

Unique keyhole-slotted mounting flanges allow these transducers to be removed and re-installed by loosening the mounting screws.

Table 1. Available Transducer Models

Model	Function
PWH Watt/Watt-Hour	Calculates true RMS power.
PVH VAR/VAR-Hour	Calculates true RMS reactive power.
PCV Watt/Watt-Hour & VAR/VAR-Hour	Combined-function unit calculates both true RMS power and true RMS reactive power.

Features

- **±0.2% of reading accuracy.** These transducers are ideal for applications where precise power measurement is demanded.
- **Measure true power.** True RMS measurement of voltage and current delivers exceptionally accurate computation of active or reactive power.
- **Two outputs (one analog, one discrete) per unit.** Each module delivers one analog (4-20mA, -1 to 1mA, etc.) and one discrete output for interface with separate SCADA systems and counting devices.
- **Electromechanical or solid state relay.** The discrete pulse output can be electromechanical or solid state. This choice allows easy interface with nearly any accumulating device.
- **No zero adjustment required.** These stable transducers feature a zero adjustment that never needs re-adjustment after the initial factory setting.
- **Complete isolation.** Input/output isolation stops measurement inaccuracies caused by ground loops.

PCV, PVH & PWH

AC Energy Transducers

Specifications

Characteristics		Performance (continued)	Performance (continued)
Performance	Accuracy @ 25°C, ±2°C: Watt: 0.19% of reading/ Cos ϕ ±0.01% of full scale VAR: 0.019% of reading/ Sin ϕ ±0.01% of full scale Operating Frequency: 60Hz standard Output Ripple (peak): <0.5% of full scale Burden: Input Current: 0.05VA Input Voltage: 0.02VA Auxiliary Power Voltage: PVH, 5.0VA; PWH, 4.0VA;	PCV, 6.0VA (add this value to the input voltage value to determine burden of self-powered units) Dielectric Test: 2000Vrms for one minute Response Time: To 90%, <100ms; To 99%, <200ms Overload Capability: Voltage Input: 1.5 times the nominal input value Current Input: See Table 2	Surge Withstand Capability: ANSI-C37.90a-1974 (IEEE 472) BEAMA 219, SPECIAL 5KV, 0.6KV B.I.L. (basic insulation level) Ambient Temperature Range: -20°C to +70°C (-4°F to +158°F) Effect: 0.005%/°C (±0.003%/°F) Adjustments Type: External multiturn potentiometers Span: ±10% of rated output Zero: ±2% of rated output

Ordering Specifications

Unit	Input	Analog Output	Discrete Pulse Rate	Relay Type	Configuration	Options	Housing
PVH VAR/VAR-Hour Transducer PWH Watt/Watt-Hour Transducer PCV Combination Watt/Watt-Hour & VAR/VAR-Hour Transducer	Specify one each Voltage Input and Current Input from Table 3 (see Table 4 for factory calibration information; see -SPC option if special calibration is required)	(-1)-1MA into 15,000 ohms (0mA = 0%) 4-20MA into 750 ohms (PWV watt output is 4-20mA, VAR output is 4-12-20mA with 12mA = 0%) 4-20MAB 4-12-20mA into 750 ohms (12mA = 0%)	Specify full scale frequency in counts per hour; Min. = 10 cph (500 cph with PRB or RMB relay types) Max. = 20,000 cph	See Table 4 for descriptions: PRU PRB RMU RMB	See Table 5 for descriptions: 1E 1.5E 2E 2.5E 3E	-.09 Provides ±0.09% of reading, ±0.02% of full scale accuracy -50H 50Hz input/operating frequency -400H 400Hz input/operating frequency -120AC 85-150Vac auxiliary power -240AC 170-300Vac auxiliary power -CAL With full scale input, provides adjustment of output signal from 25% to 125% of full scale -CG Case ground terminal -Q Replaces VAR and VAR-hour output with Q output Q = Elcos (ϕ -60) -SPC Special calibration to values other than listed in Table 4	SM Surface-mount housing DM DIN-style rail-mount housing

To order, specify: Unit / Input (nominal input voltage, full scale input current) / Output (analog signal), Discrete Output Pulse Rate & Relay Type / Configuration / Options [Housing]

Model number example: PWH / 120AC, 5A / 4-20MA, 1000RMU / 2E / -120AC [SM]

Table 2. Current Input Overload Capability

Input	Overload Continuous	Overload 10 Sec/Hour	Overload 1 Sec/Hour
0-1A	3A	6A	100A
0-2A	6A	12A	150A
0-5A	15A	30A	250A
0-10A	35A	75A	300A
0-25A	35A	75A	300A

Ordering Specifications

To order, use the bold face data from the "Ordering Specifications" section of the Specifications table. For assistance, refer to the model number example located at the bottom of the table.

Table 3. Input Selection.

Voltage Input (nominal)*			Current Input (nominal)		
Ordering Code	Range with Self-Power	Range with Auxiliary Power	Ordering Code	Nominal Range	Maximum Range
69AC	50-80Vac	0-90Vac	1A	0-1 amp	0-2 amps
120AC	85-135Vac	0-150Vac	2A	0-2 amps	0-5 amps
240AC	170-300Vac	0-300Vac	5A	0-5 amps	0-10 amps
460AC	325-515Vac	0-575Vac	10A	0-10 amps	0-20 amps
600AC	425-675Vac	0-750Vac	25A	0-25 amps	0-35 amps

*Specify line to neutral voltage on 3-phase, 4-wire circuits (e.g., specify 240AC for a 480Y277 circuit)

Table 4. Standard Calibration.*

Watts or VARs Per Element**:					
Voltage Input	Current Input				
	1A	2A	5A	10A	25A
69AC	65	130	325	650	1625
120AC	100	200	500	1000	2500
240AC	200	400	1000	2000	5000
460AC	400	800	2000	4000	10000
600AC	500	1000	2500	5000	12500

*A unit with 120AC, 5A indicated in the input field of the model number will be calibrated to 500 Watts or VARs per element. (e.g., 20mA will represent 1000 Watts or VARs).

**1.5 element units are calibrated as 2 element units; 2.5 element units are calibrated as 3 element.

Table 6. Configuration Selection.

Ordering Code	Application	Circuit Type (No. of elements)	Restrictions	
			Voltage	Load
1E	1 Element	1-Phase, 2-Wire	None	None
1.5E	1-1/2 Element	3-Phase, 3-Wire	Balanced	Balanced
2E	2 Element	3-Phase, 3-Wire	None	None
2.5E	2-1/2 Element	3-Phase, 4-Wire	Balanced	None
3E	3 Element	3-Phase, 4-Wire	None	None

Table 5. Relay Type Descriptions

Ordering Code	Description
PRU	One solid-state opto-coupler relay; single-pole, single-throw (SPST), momentary closure per pulse; open NPN collector transistors, 1.5W, 50V maximum
PRB	Two solid-state opto-coupler relays, one for forward energy accumulation, the other for reverse energy accumulation; single-pole, single-throw (SPST), momentary closure per pulse; open NPN collector transistors, 1.5W, 50V maximum
RMU	One electromechanical single-pole, double-throw (Form C) relay; mercury wetted contacts; bi-stable, latching relay latches in a new position for each count, alternating between the two poles as the pulses are accumulated (Contact Rating: 2A max., 100 Watts max., 500V max; Contact Resistance: 200 milliohms max.)
RMB	Two electromechanical single-pole, double-throw (Form C) relays, one for forward energy accumulation, the other for reverse energy accumulation; mercury wetted contacts; bi-stable, latching relay latches in a new position for each count, alternating between the two poles as the pulses are accumulated (Contact Rating: 2A max., 100 Watts max., 500V max; Contact Resistance: 200 milliohms max.)

PCV, PVH & PWH

AC Energy Transducers

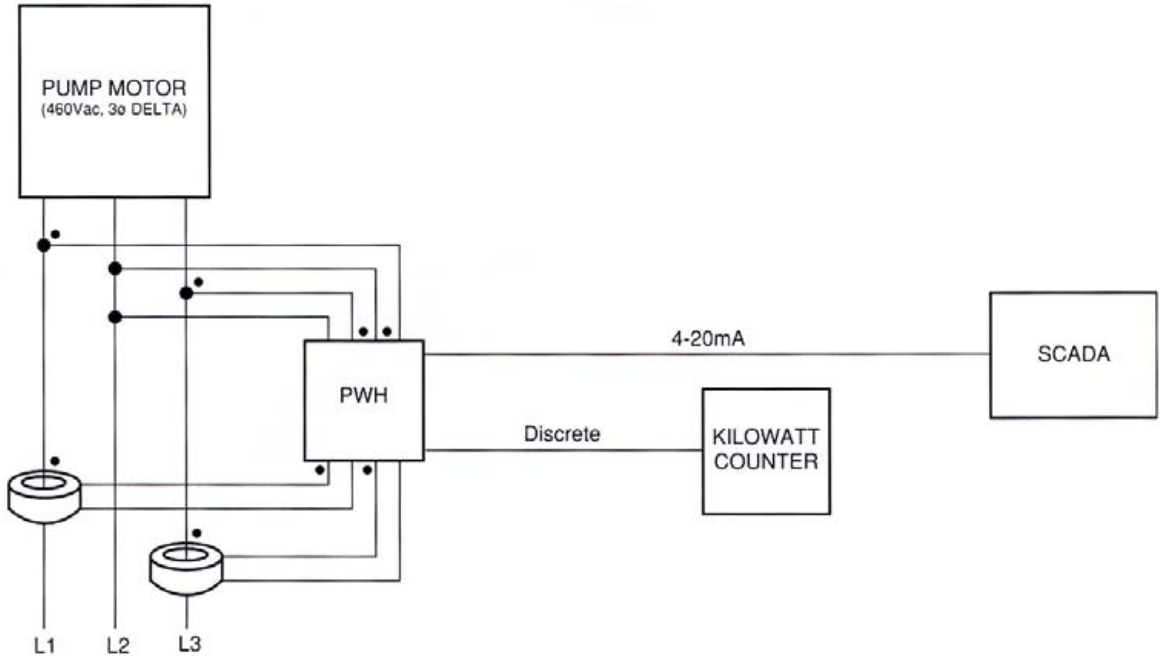

Figure 1. Moore Industries' AC Energy Transducers produce an analog output for direct input to the SCADA, and a pulse output for interface with a counter.

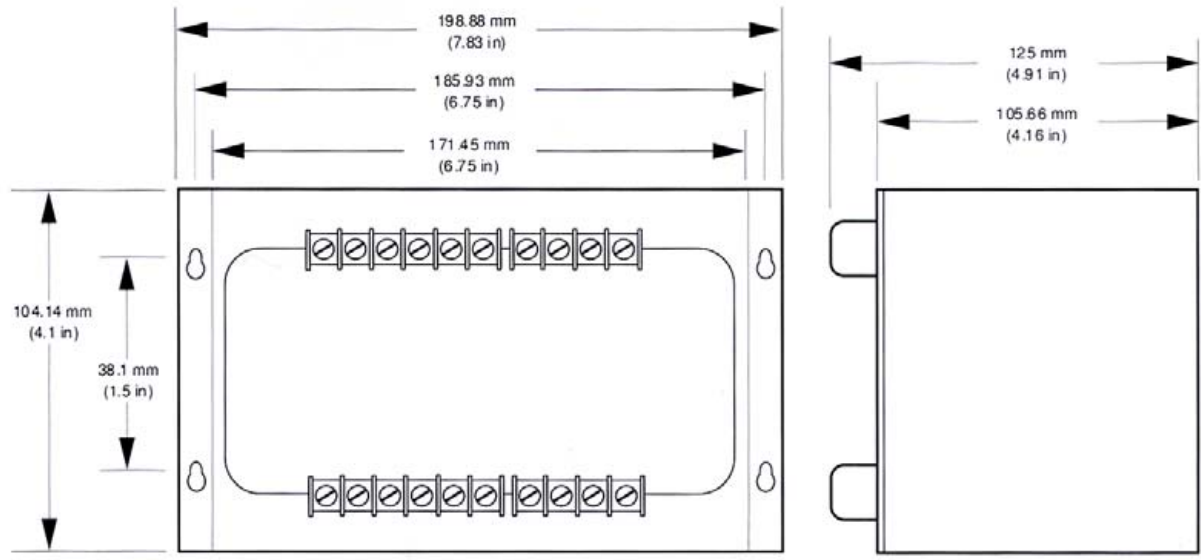

Figure 2. Outline Dimensions

PCV, PVH & PWH

AC Energy Transducers

Figure 3. PVH and PWH Terminal Designations

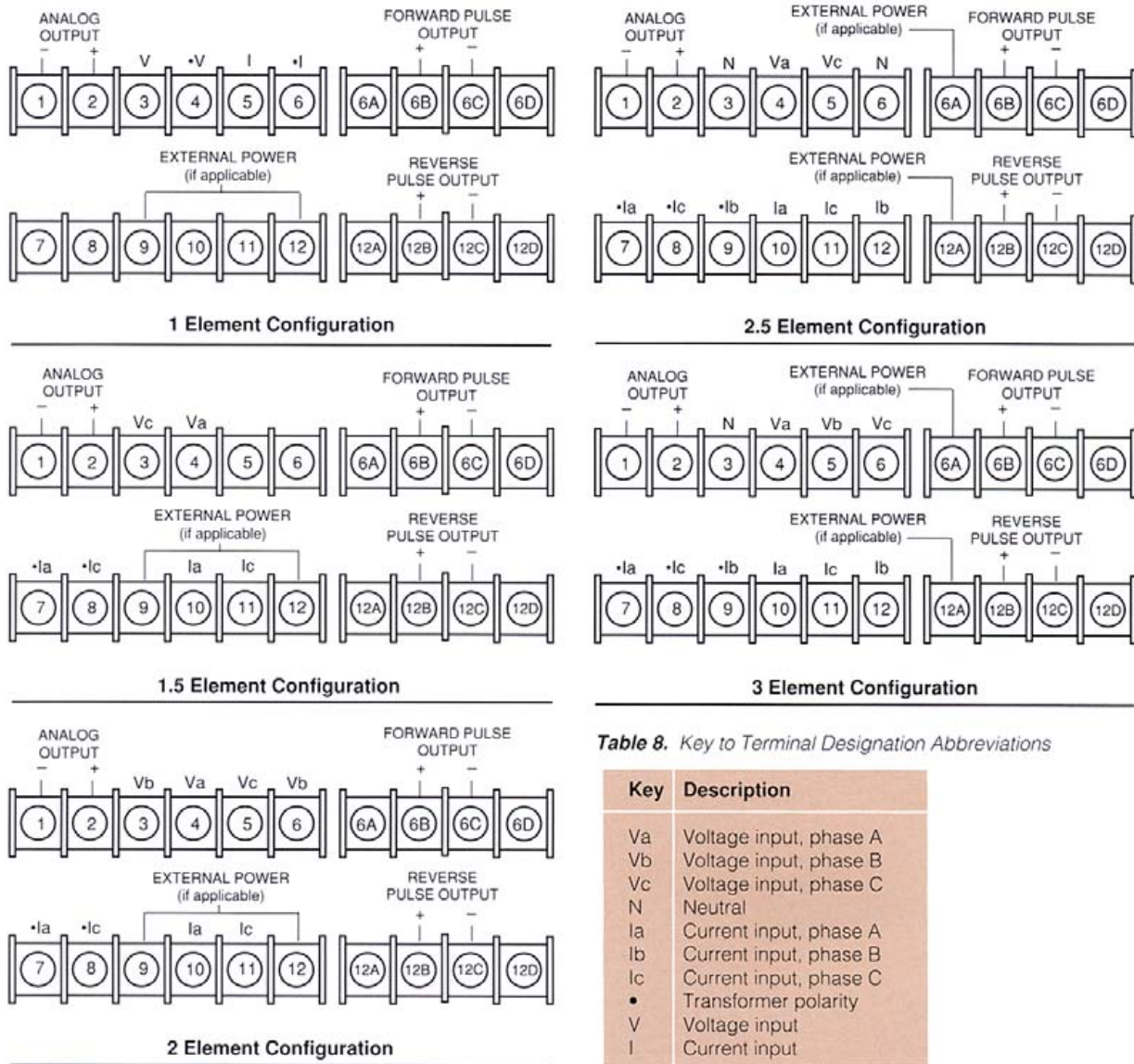
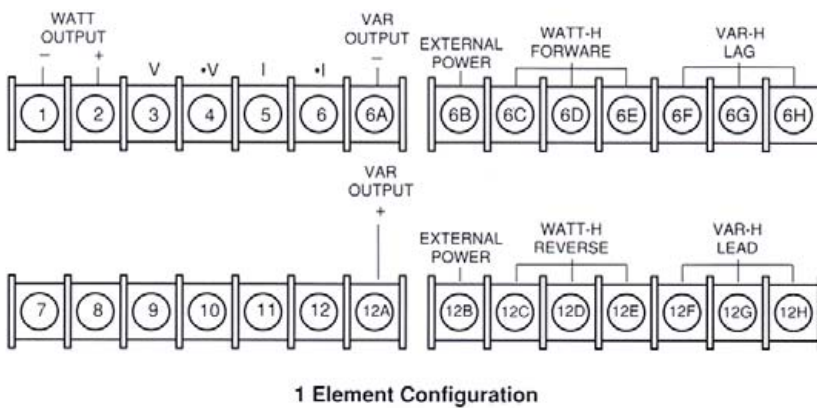

Table 8. Key to Terminal Designation Abbreviations

Key	Description
Va	Voltage input, phase A
Vb	Voltage input, phase B
Vc	Voltage input, phase C
N	Neutral
Ia	Current input, phase A
Ib	Current input, phase B
Ic	Current input, phase C
•	Transformer polarity
V	Voltage input
I	Current input

Figure 3. PCV Terminal Designations



PCV, PVH & PWH

AC Energy Transducers

Figure 3. PCV Terminal Designations (continued)

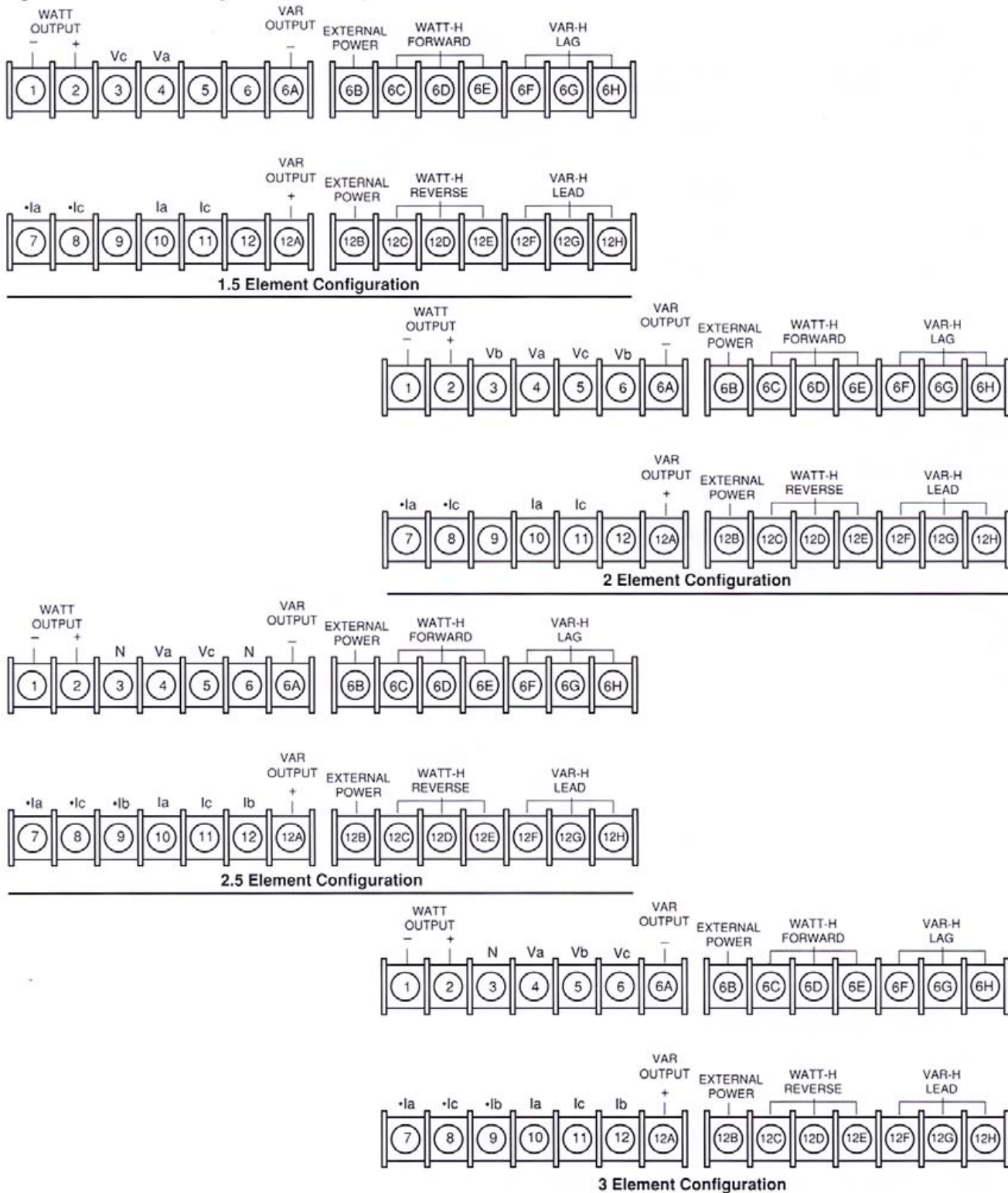

The Interface Solution Experts

United States
Tel: (818) 894-7111
FAX: (818) 891-2816

Australia
Tel: (02) 525-9177
FAX: (02) 525-7296

Belgium
Tel: 03/235.35.44
FAX: 03/271.00.17

Netherlands
Tel: (0)344-617971
FAX: (0)344-615920

United Kingdom
Tel: 01293 514488
FAX: 01293 536852