

ACX AC Current Transmitter



The ACX

The 2-wire ACX accepts standard AC inputs from current and potential transformers and converts them to a proportional current or voltage signal. This signal can be used to monitor motor currents and interface with process instruments, such as distributed control systems.

The DIN-style ACX incorporates an internal toroidal input transformer that steps a 0-5A input down to 0-5mA. The transformer also isolates the input and enables the ACX to withstand large momentary overloads such as start-up or in-rush current.

For additional safety, the ACX can be ordered with the toroidal input transformer (-EM option) mounted outside the unit. This option is required for current input units that need RFI/EMI protection. In addition, it allows the user to remove the ACX from service without disturbing the process current.

The ACX is offered with a variety of other options. For details, see the ordering information at the bottom of the page.

Specifications

Performance Calibration Capability: ±0.2% of span (linearity and repeatability); ±0.5% of span at 0-10Vac range and lower Isolation: Input and output are transformer isolated up to 500Vdc Overload Capability: 35 amps for 30 seconds with -EM option; 150% overvoltage with voltage input	Performance (continued) Load Capability: $R \text{ (load)} = \frac{E - 12}{I}$ Ripple: 10mV peak-to-peak maximum Ambient Temperature Range: -20 to +82°C (-4 to +180°F) Effect: ±0.015%/°C (±0.01%/°F) over above range	Adjustments Type: External multiturn potentiometers Span: With full scale input, adjusts output to 100%, ±10% of selected output span Weight 170 grams (6 ounces)
---	--	--

Specifications subject to change without notice

Ordering Information

Unit	Input	Output	Power	Options	Housing
ACX	Current (into 0.1 ohms input impedance) 0-1AAC 0-2AAC 0-3AAC 0-4AAC 0-5AAC Voltage (into 100 ohms per volt input impedance) 0-.5VAC 0-1.5VAC 0-5VAC 0-10VAC 0-25VAC 0-50VAC 0-120VAC 0-150VAC	4-20MA into 600 ohms with 24Vdc power supply 10-50MA into 600 ohms with 42Vdc power supply	12-42DC (loop-powered on output side)	-EM Externally-mounted input transformer for current input (required for the current-input version of the hockey-puck housing) -FA Front Accessible terminal block (DIN housing only)* -RF RFI/EMI protection (requires -EM option for current input); Housings rate 50V/m -ABC = 0.1% F.S. when tested according to SAMA Standard PMC 33.1 -RTB Removable Terminal Block (DIN housing only)	DIN Aluminum DIN-style rail-mount housing (G-type rail) HP Hockey-puck housing with spring clips for mounting in an explosion-proof enclosure FL Hockey-puck housing with flanges for surface or relay track mounting 2LS* Hockey-puck housing mounted in a 2-hub, solid cover, low dome, explosion-proof enclosure <small>*F (prefix) indicates CENELEC approved (e.g. F2LS) FM (prefix) indicates FM approved (e.g. FM2LS) S (prefix) indicates SAA approved (e.g. S2LS) P (suffix) indicates unit comes equipped with a base plate and U-bolts for mounting on a 2-inch pipe (e.g. 2LSP)</small>

When ordering, specify: Unit / Input / Output / Power / Options [Housing]
Model number example: ACX / 0-5AAC / 4-20MA / 12-42DC / -EM -FA [DIN]

Calibration

A quick bench check of basic operation is needed to set zero and span and to ensure that the unit hasn't sustained any damage during transit.

Calibration Setup

The equipment in Table 1 is needed to calibrate the ACX. These items are not supplied by Moore Industries, but are available in most testing labs. Use calibrated test equipment when performing the bench check and zero/span adjustment of the ACX. The use of inaccurate test equipment could result in unreliable settings and costly process down time.

These procedures should be performed in an area considered appropriate for general testing of electronic equipment. Use a technician's bench or similar, lab-type environment.

Table 1. ACX Calibration Equipment

Equipment	Specification
Screwdriver	Blade less than 0.1 inch (2.54mm)
Adjustable AC Current or Voltage Source	Simulates appropriate input signal levels
DC Voltmeter (Voltage outputs only)	Accurate to within $\pm 0.01\%$ or better
DC Milliammeter (Current outputs only)	Accurate to within $\pm 0.01\%$ or better
AC Ammeter	Accurate to within $\pm 0.01\%$ or better
24Vdc Power Supply	50mA or more, unregulated

CAUTION:

Do not connect a 0-5A input directly to an ACX that has an -EM option. Any ACX with the -EM option requires the use of the externally mounted current step-down transformer that is shipped with the unit.

Calibration Procedure

The ACX's ZERO and SPAN adjustments are the 22-turn potentiometers located on the front panel of the unit. Turning the shaft clockwise increases the quantity, while turning the shaft counterclockwise decreases the quantity.

Before beginning this procedure, check the model number of the unit to be calibrated to verify the unit's power requirements and its input and output configurations. The following procedure is suitable for all ACX's:

1. Connect the ACX as shown in Figure 1 or 2, as appropriate.
2. Apply Power
3. Adjust the input to 0%. (For example, if the ACX input is 0-5A, adjust the input to 0A)
4. Turn the ZERO potentiometer until the metered output is 0%.
5. Adjust the input to 100% (full scale). (For example, if the ACX input is 0-5A, adjust the input to 5A)
6. Turn the SPAN potentiometer until the metered output is 100%.
7. Repeat steps 3 through 6 until the output is stable at 0% and 100% output.
8. Apply 25%, 50%, and 75% of the maximum input and verify that the ACX's output varies with the input.
9. Remove the input and turn off the power to the unit.

Figure 1. Calibrating the DIN ACX WITHOUT the -EM option

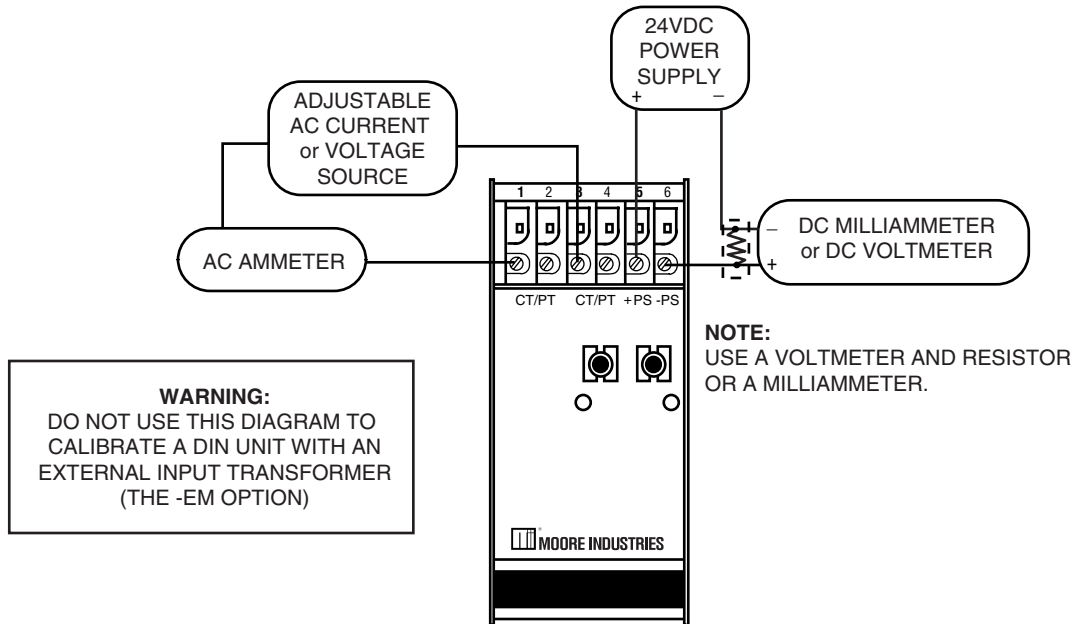
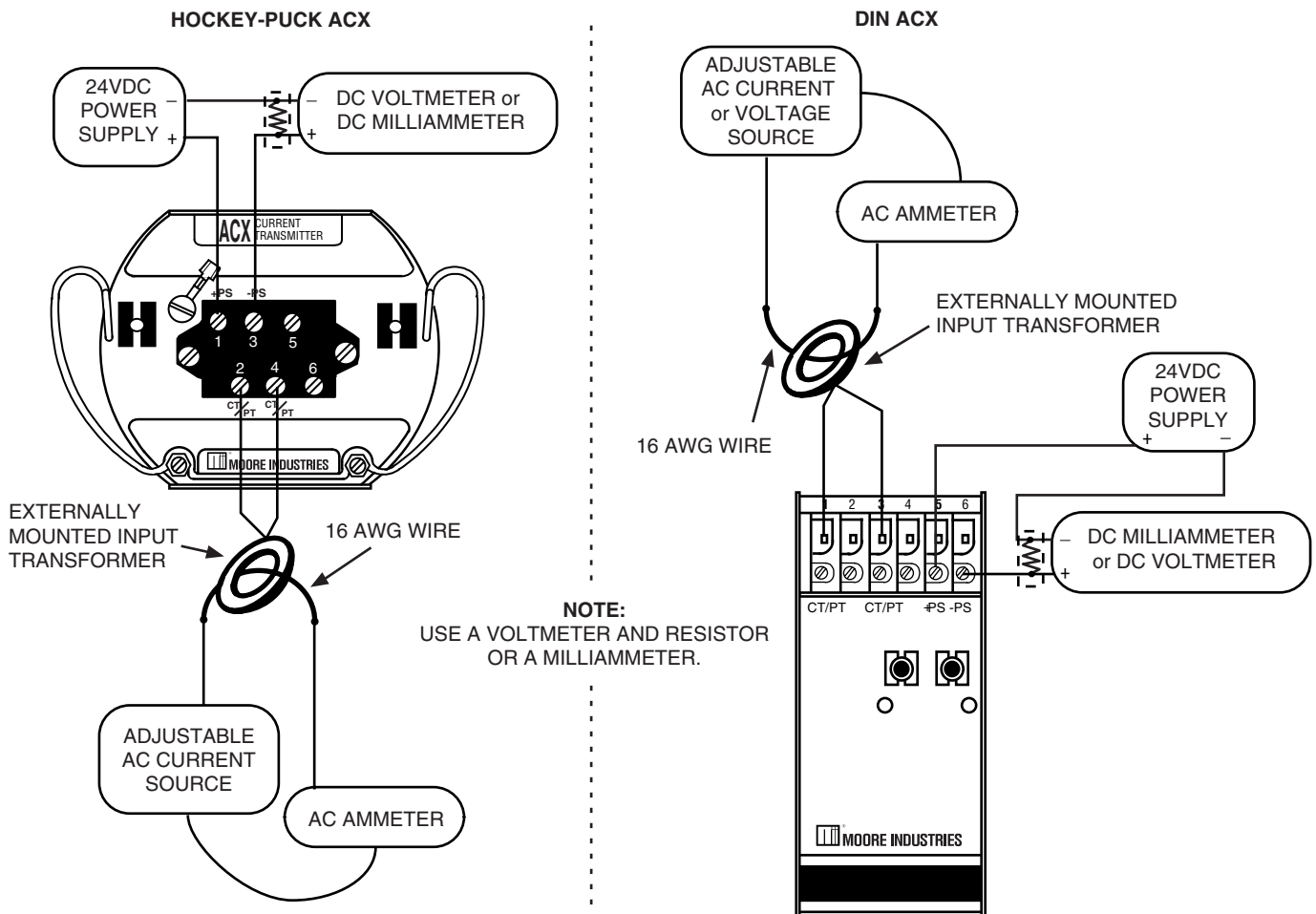

Figure 2. Calibrating the HP and DIN ACX's with -EM option



ACX

Installation

Before installing the ACX, you should bench check it to ensure that it is configured for its intended application. To install the ACX, mount the unit and make the electrical connections.

Mounting the ACX

The ACX is available in DIN-style and Hockey-puck style housing. The long-term reliability of the ACX is greatly enhanced when mounted in an area free of excessive dust, moisture, or corrosive elements.

Din-style Housing. Figure 3 shows the dimensions of the DIN-style ACX. To mount the unit on G-type rail, seat the extrusion under the top lip of the rail and pivot downward.

HP Housing. Figure 4 shows the dimensions of the HP style unit with the -FL housing option for surface or relay mounting. The spring clips have no dimensional significance.

Figure 3. Dimensions of ACX DIN housing

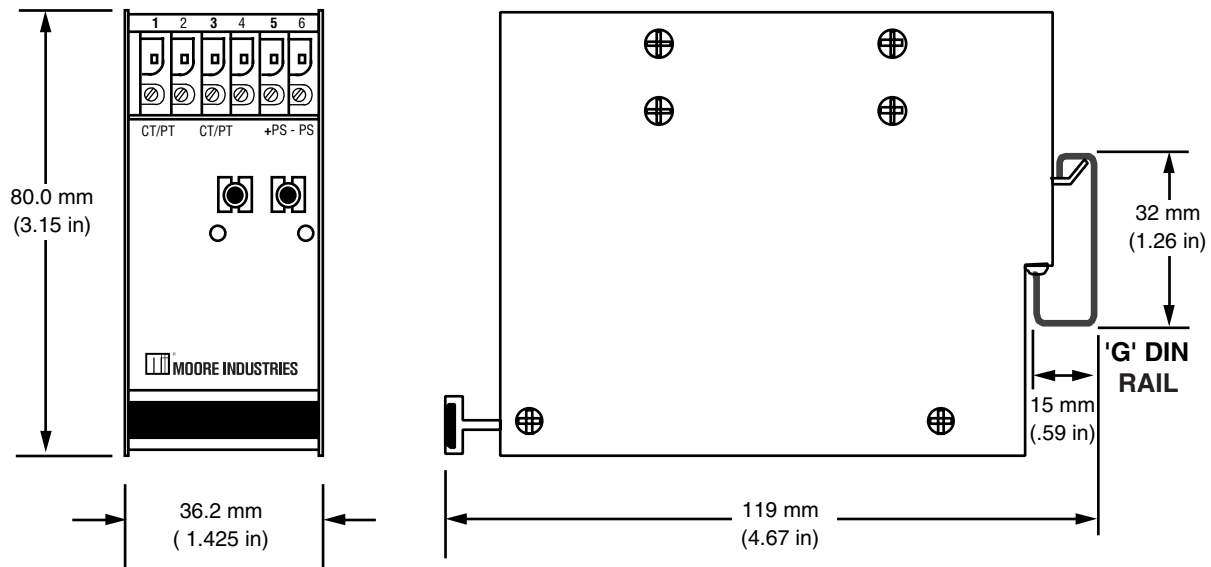
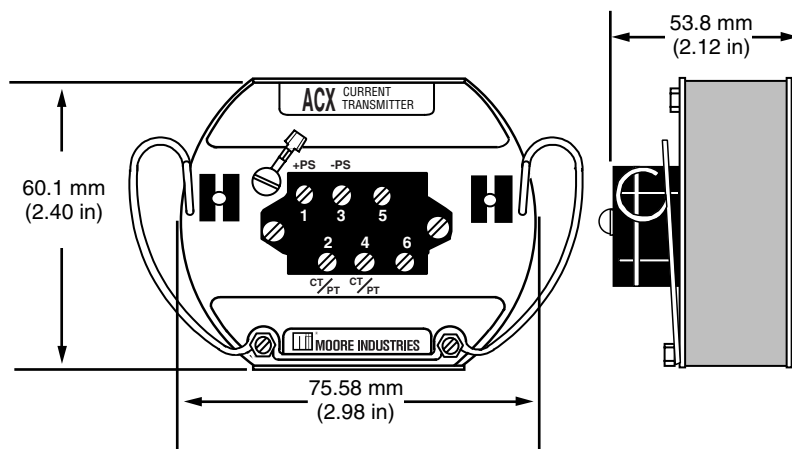

Figure 4. Dimensions of ACX Hockey-puck housing



Electrical Connections

Din-style Housing. All electrical connections to the DIN-style ACX without the -EM option are made to the terminal block. See Figure 5 for these connections or Figure 6 for connections with -EM option.

Figure 5. Connecting the DIN ACX without the -EM Option

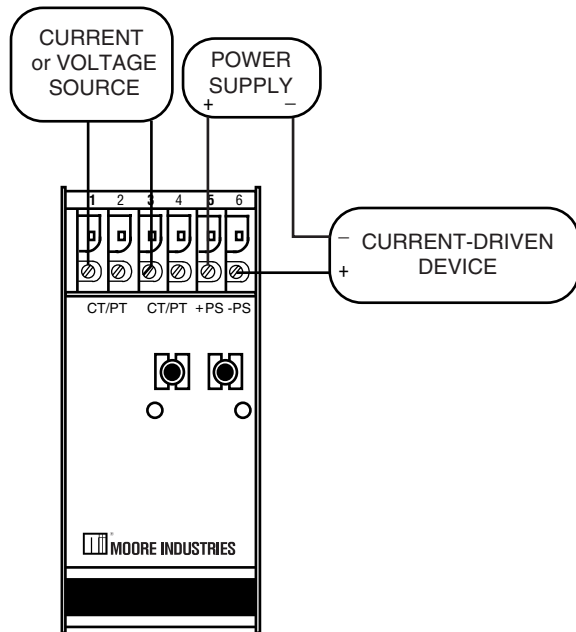

HP-style Housing. HP-style ACX's are designed to work with only one of two types of input: current or voltage. Check your model number to determine whether you have a current or a voltage model before connecting your unit.

Hook up voltage inputs directly to the unit. Units set up for current inputs that have the -EM option must be attached to the external current input transformer, *not directly to the unit*. Mount the external transformer in an appropriate location near the ACX (see figures 6 & 7).

CAUTION:

Do not connect current input directly to the HP-style ACX or DIN-style with -EM option.

For current input, connect a single strand of 16 AWG wire through the toroid, as indicated in Figure 7. Connect the two ends of the conductor to the 0-5 amp input source.

Figure 6. Connecting the HP or DIN ACX with the -EM Option

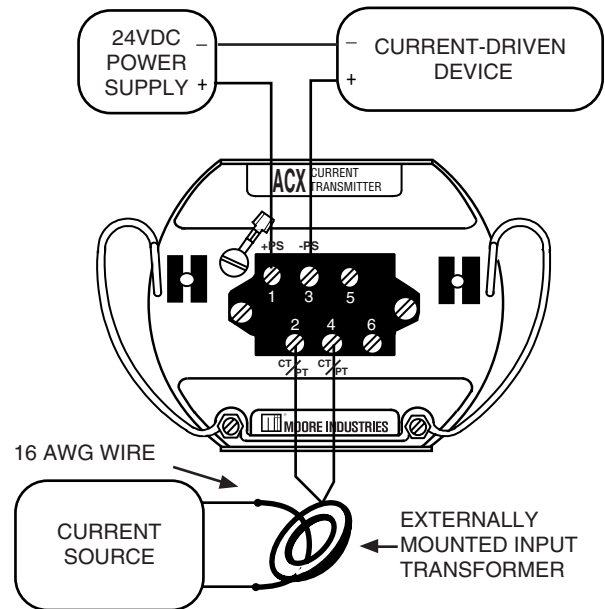

WARNING:

Opening the secondary of the current transformer while current is flowing in the primary can create potentially lethal voltages. Turn off the power to the process current transformer before threading leads through the toroidal core of the ACX's external input transformer or attaching 0-5A leads to the terminals of the ACX with an internal step-down transformer.

Figure 7. Mounting the Input Transformer

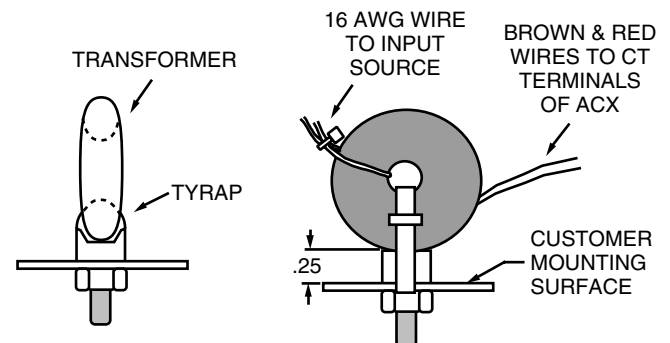

The red and brown transformer leads become the secondary with an output current of 0-5mA. Connect these leads to the ACX input terminals. Terminal connections for external transformers (units with the -EM option) are shown in Figure 6.

Recommended Ground Wiring Practices

The following ground wiring practices must be followed to ensure proper performance of the ACX:

- Any Moore Industries product in a metal case or housing should be grounded
- All input signals to, and output signals from, Moore Industries' products should be wired using a shielded, twisted pair technique. Shields are to be connected to an earth or safety ground at the unit itself.
- The maximum length of any unshielded input and/or output signal wiring is 2 inches.

CE Conformity

Installation of any Moore Industries products that carry the CE certification ***must*** adhere to the guidelines above in order to meet the requirements set forth in applicable EMC directives (EN55011, EN 50082-1, EN 50082-2, etc.)

Maintenance

Maintenance of the ACX is limited to keeping the input and output terminals and conductors clean and tight. It is recommended that the user check the terminals every six months to verify that they are secure and free of oxidation. A thorough cleaning of the terminal blocks requires complete disassembly and should only be done at a Moore Industries-International factory.

You may wish to periodically check performance of the ACX to ensure that it is operating within the desired parameters. To check its operational performance, remove the unit from the application and set it up for a bench check by using the calibration equipment and hookup information contained in the Calibration section. Apply a known input to the ACX and monitor its output for a predictable result. If the output is unacceptable, recalibrate the unit using the procedures on page 2.

If the unit is still performing below specifications, use the information on the back cover of this manual to contact the factory.

RETURN PROCEDURES

To return equipment to Moore Industries for repair, follow these four steps:

1. Call Moore Industries and request a Returned Material Authorization (RMA) number.

Warranty Repair –

If you are unsure if your unit is still under warranty, we can use the unit's serial number to verify the warranty status for you over the phone. Be sure to include the RMA number on all documentation.

Non-Warranty Repair –

If your unit is out of warranty, be prepared to give us a Purchase Order number when you call. In most cases, we will be able to quote you the repair costs at that time. The repair price you are quoted will be a "Not To Exceed" price, which means that the actual repair costs may be less than the quote. Be sure to include the RMA number on all documentation.

2. Provide us with the following documentation:
 - a) A note listing the symptoms that indicate the unit needs repair
 - b) Complete shipping information for return of the equipment after repair
 - c) The name and phone number of the person to contact if questions arise at the factory
3. Use sufficient packing material and carefully pack the equipment in a sturdy shipping container.
4. Ship the equipment to the Moore Industries location nearest you.

The returned equipment will be inspected and tested at the factory. A Moore Industries representative will contact the person designated on your documentation if more information is needed. The repaired equipment, or its replacement, will be returned to you in accordance with the shipping instructions furnished in your documentation.

WARRANTY DISCLAIMER

THE COMPANY MAKES NO EXPRESS, IMPLIED OR STATUTORY WARRANTIES (INCLUDING ANY WARRANTY OF MERCHANTABILITY OR OF FITNESS FOR A PARTICULAR PURPOSE) WITH RESPECT TO ANY GOODS OR SERVICES SOLD BY THE COMPANY. THE COMPANY DISCLAIMS ALL WARRANTIES ARISING FROM ANY COURSE OF DEALING OR TRADE USAGE, AND ANY BUYER OF GOODS OR SERVICES FROM THE COMPANY ACKNOWLEDGES THAT THERE ARE NO WARRANTIES IMPLIED BY CUSTOM OR USAGE IN THE TRADE OF THE BUYER AND OF THE COMPANY, AND THAT ANY PRIOR DEALINGS OF THE BUYER WITH THE COMPANY DO NOT IMPLY THAT THE COMPANY WARRANTS THE GOODS OR SERVICES IN ANY WAY.

ANY BUYER OF GOODS OR SERVICES FROM THE COMPANY AGREES WITH THE COMPANY THAT THE SOLE AND EXCLUSIVE REMEDIES FOR BREACH OF ANY WARRANTY CONCERNING THE GOODS OR SERVICES SHALL BE FOR THE COMPANY, AT ITS OPTION, TO REPAIR OR REPLACE THE GOODS OR SERVICES OR REFUND THE PURCHASE PRICE. THE COMPANY SHALL IN NO EVENT BE LIABLE FOR ANY CONSEQUENTIAL OR INCIDENTAL DAMAGES EVEN IF THE COMPANY FAILS IN ANY ATTEMPT TO REMEDY DEFECTS IN THE GOODS OR SERVICES, BUT IN SUCH CASE THE BUYER SHALL BE ENTITLED TO NO MORE THAN A REFUND OF ALL MONIES PAID TO THE COMPANY BY THE BUYER FOR PURCHASE OF THE GOODS OR SERVICES.

ANY CAUSE OF ACTION FOR BREACH OF ANY WARRANTY BY THE COMPANY SHALL BE BARRED UNLESS THE COMPANY RECEIVES FROM THE BUYER A WRITTEN NOTICE OF THE ALLEGED DEFECT OR BREACH WITHIN TEN DAYS FROM THE EARLIEST DATE ON WHICH THE BUYER COULD REASONABLY HAVE DISCOVERED THE ALLEGED DEFECT OR BREACH, AND NO ACTION FOR THE BREACH OF ANY WARRANTY SHALL BE COMMENCED BY THE BUYER ANY LATER THAN TWELVE MONTHS FROM THE EARLIEST DATE ON WHICH THE BUYER COULD REASONABLY HAVE DISCOVERED THE ALLEGED DEFECT OR BREACH.

RETURN POLICY

For a period of thirty-six (36) months from the date of shipment, and under normal conditions of use and service, Moore Industries ("The Company") will at its option replace, repair or refund the purchase price for any of its manufactured products found, upon return to the Company (transportation charges prepaid and otherwise in accordance with the return procedures established by The Company), to be defective in material or workmanship. This policy extends to the original Buyer only and not to Buyer's customers or the users of Buyer's products, unless Buyer is an engineering contractor in which case the policy shall extend to Buyer's immediate customer only. This policy shall not apply if the product has been subject to alteration, misuse, accident, neglect or improper application, installation, or operation. THE COMPANY SHALL IN NO EVENT BE LIABLE FOR ANY INCIDENTAL OR CONSEQUENTIAL DAMAGES.



WORLDWIDE • www.miinet.com

United States • info@miinet.com
Tel: (818) 894-7111 • FAX: (818) 891-2816

Australia • sales@mooreind.com.au
Tel: (02) 8536-7200 • FAX: (02) 9525-7296

Belgium • info@mooreind.be
Tel: 03/448.10.18 • FAX: 03/440.17.97

The Netherlands • sales@mooreind.nl
Tel: (0)344-617971 • FAX: (0)344-615920

China • sales@mooreind.sh.cn
Tel: 86-21-62491499 • FAX: 86-21-62490635

United Kingdom • sales@mooreind.com
Tel: 01293 514488 • FAX: 01293 536852